

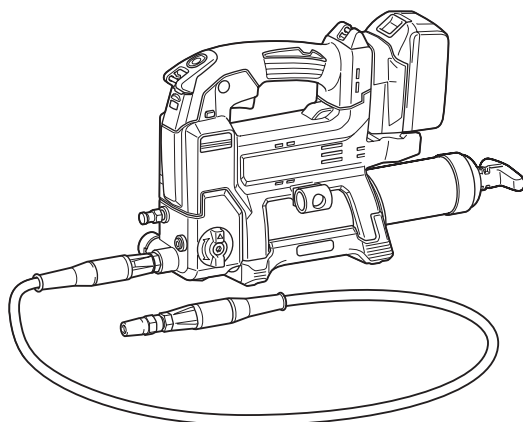

EN	Cordless Grease Gun	INSTRUCTION MANUAL	8
FR	Pompe à Graisse Sans fil	MANUEL D'INSTRUCTIONS	17
DE	Akku-Fettpresse	BETRIEBSANLEITUNG	27
IT	Ingrassatore a batteria	ISTRUZIONI PER L'USO	38
NL	Accuvetspuit	GEBRUIKSAANWIJZING	49
ES	Pistola Engrasadora Inalámbrica	MANUAL DE INSTRUCCIONES	59
PT	Aplicador de Graxa a Bateria	MANUAL DE INSTRUÇÕES	70
EL	Φορητός γρασαδόρος	ΕΓΧΕΙΡΙΔΙΟ ΟΔΗΓΙΩΝ	80
TR	Akülü Gres Tabancası	KULLANMA KILAVUZU	91

DGP180

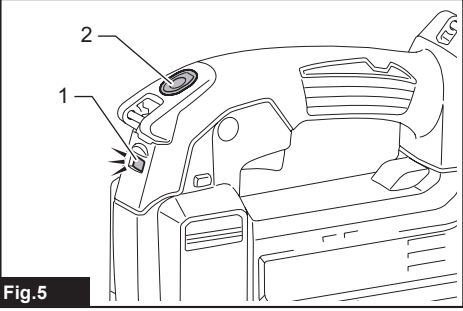

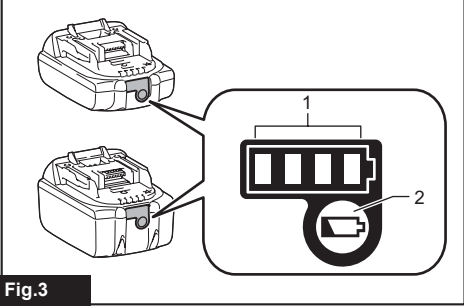
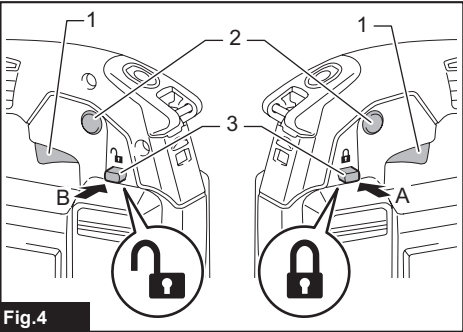
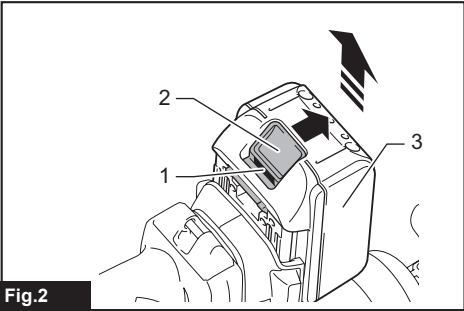
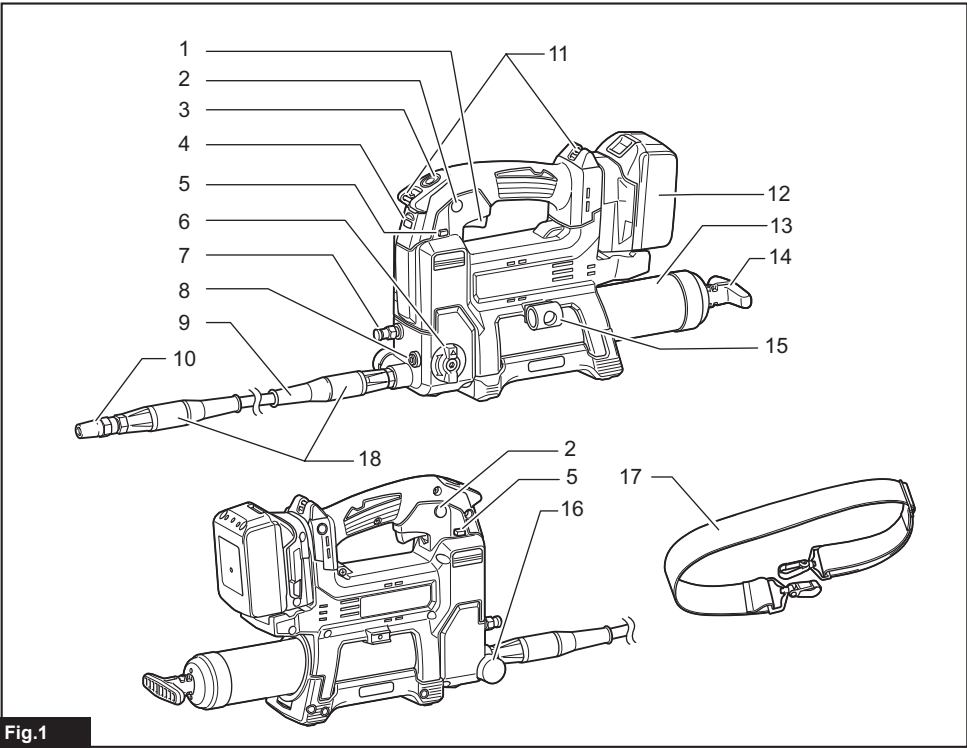

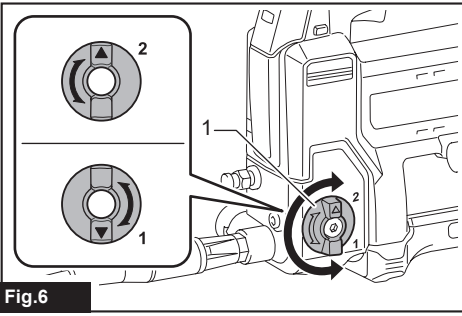

Fig.6

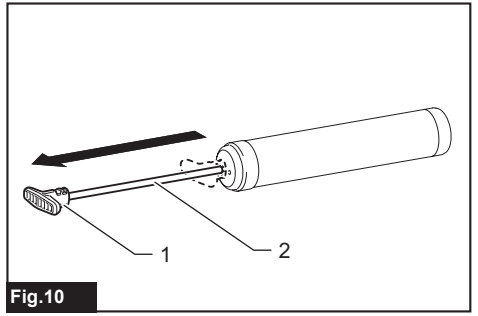

Fig.10

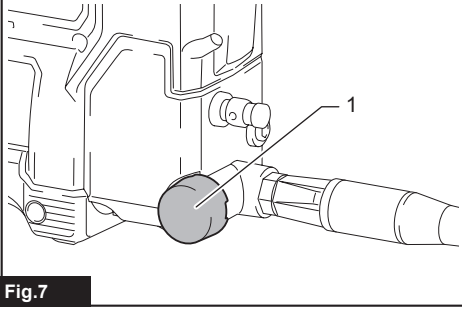

Fig.7

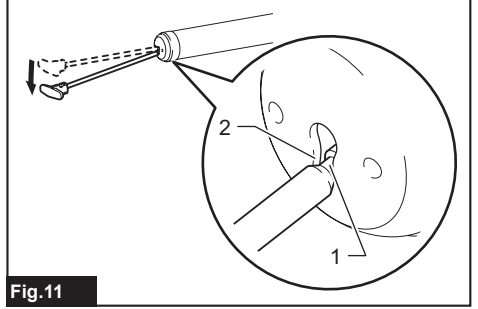

Fig.11

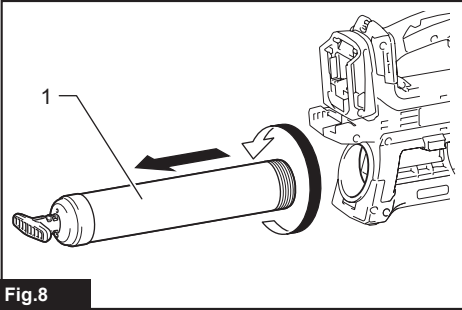

Fig.8

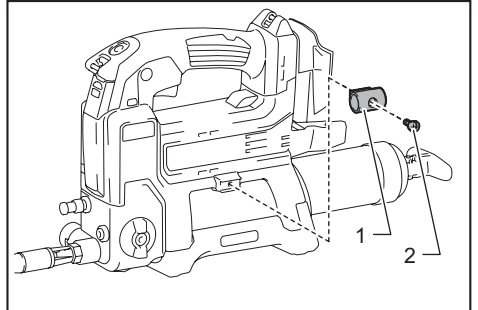

Fig.12

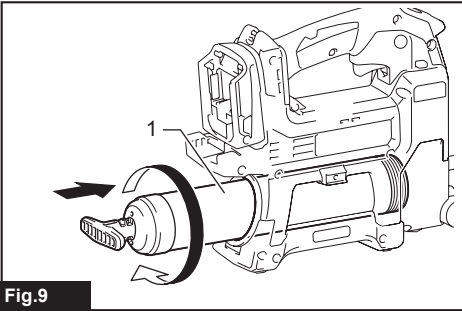
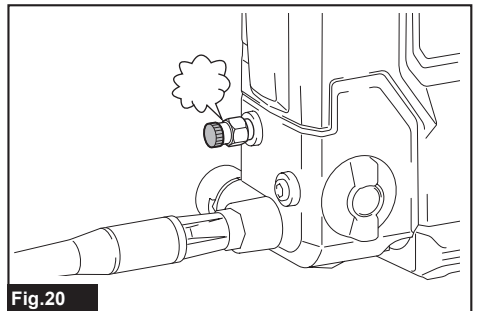
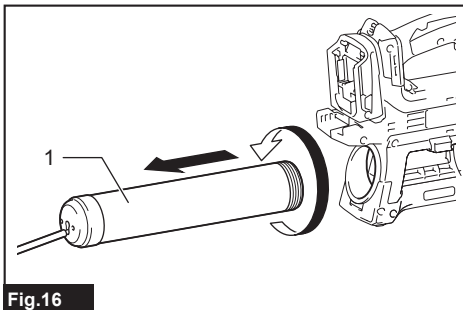
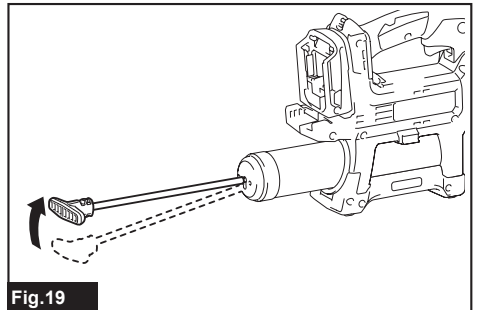
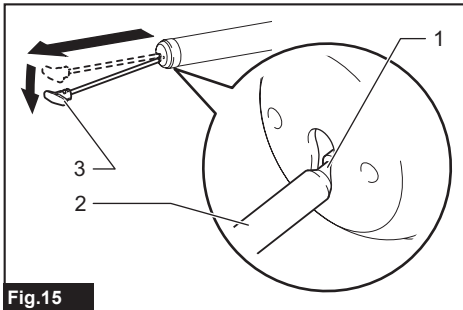
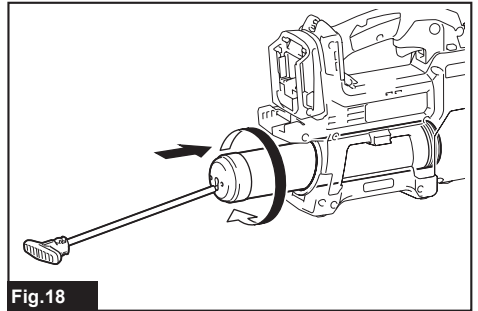
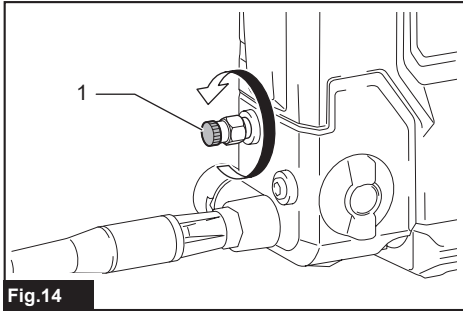
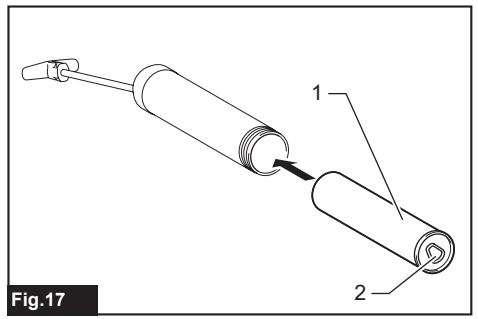
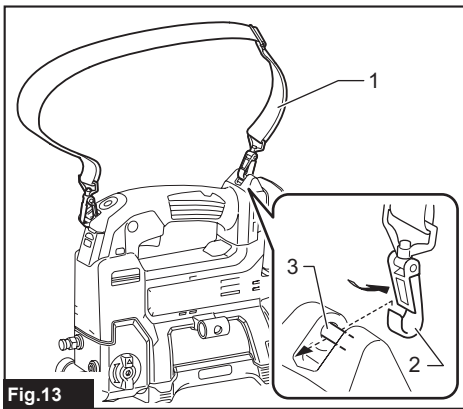

Fig.9



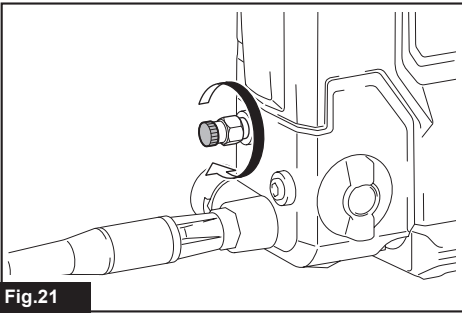

Fig.21

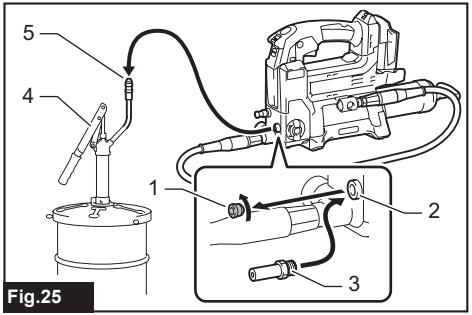

Fig.25

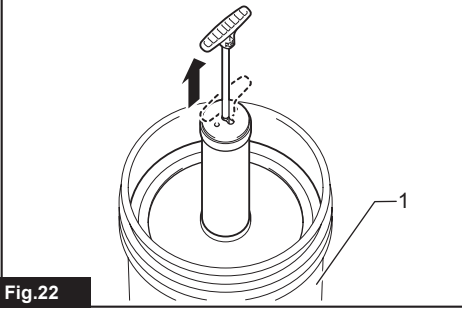

Fig.22

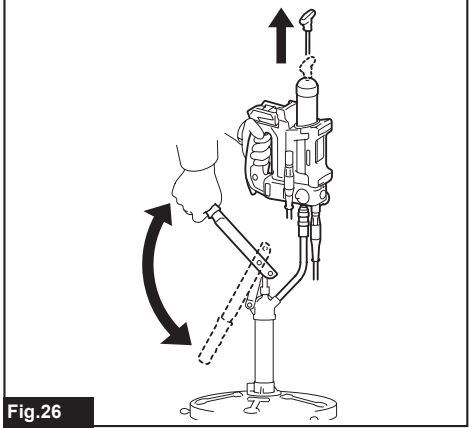

Fig.26

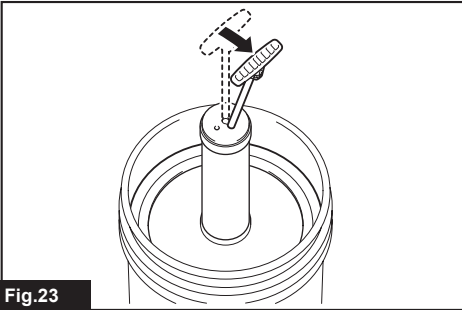

Fig.23

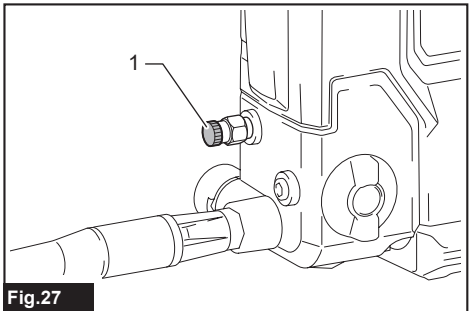

Fig.27

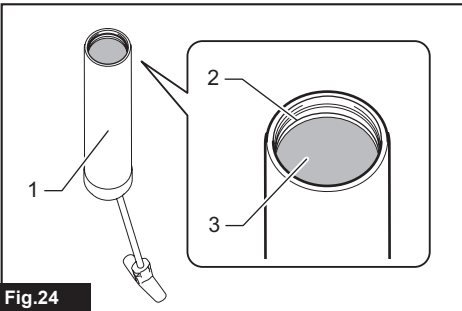

Fig.24

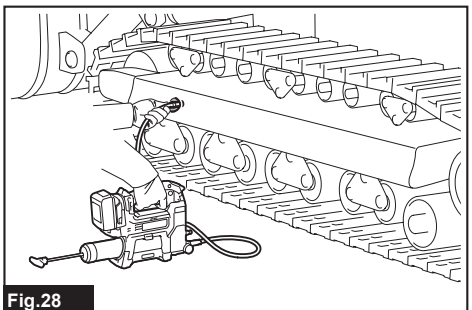

Fig.28

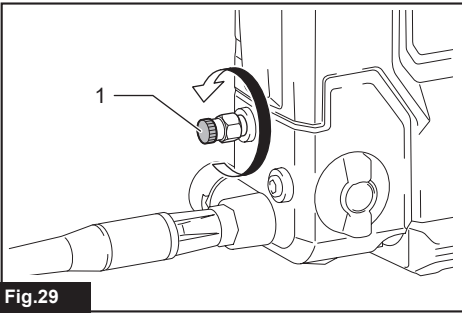

Fig.29

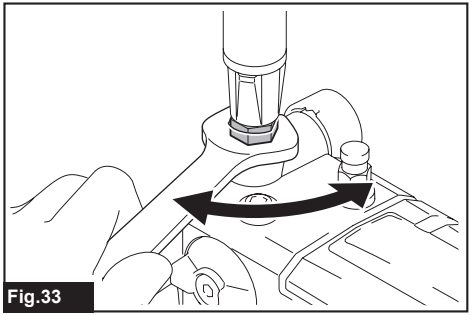

Fig.33

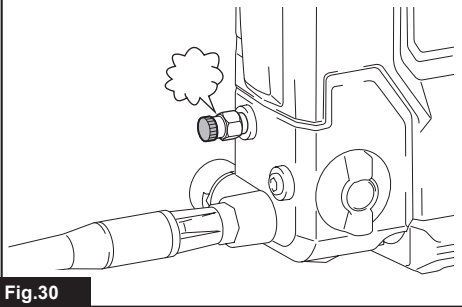

Fig.30

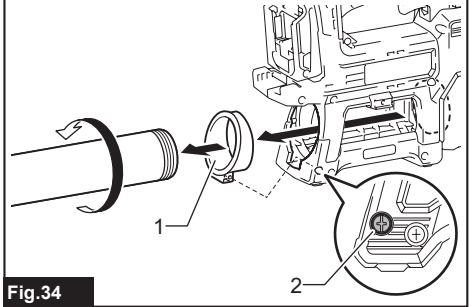

Fig.34

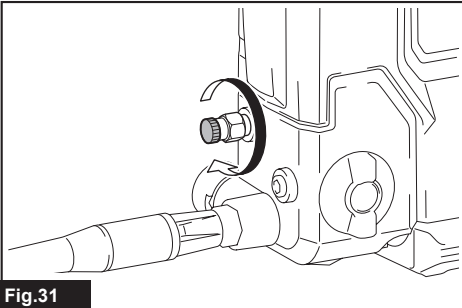

Fig.31

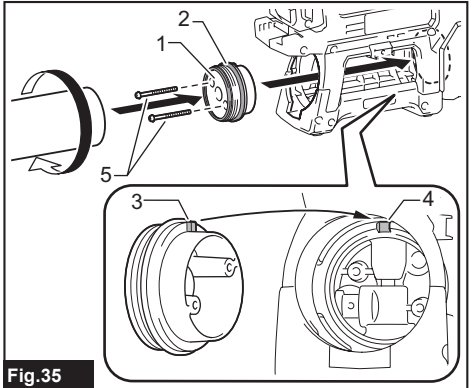

Fig.35

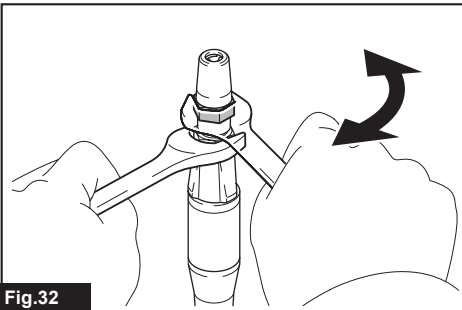

Fig.32

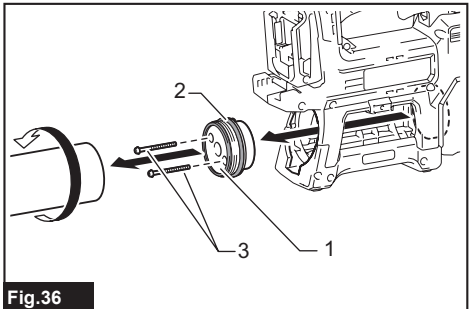
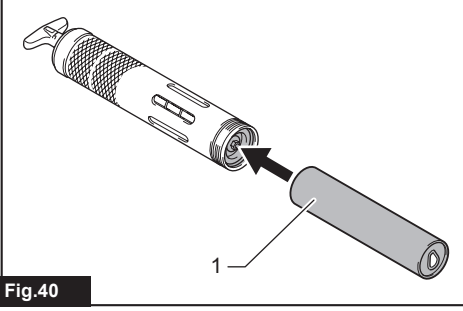
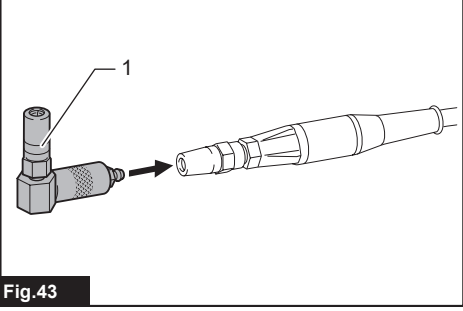
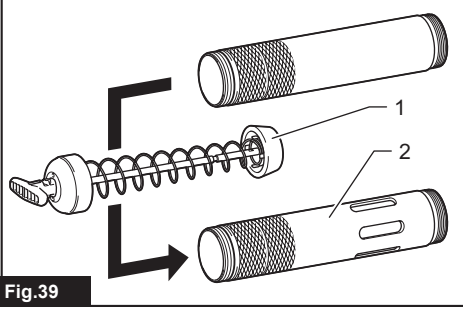
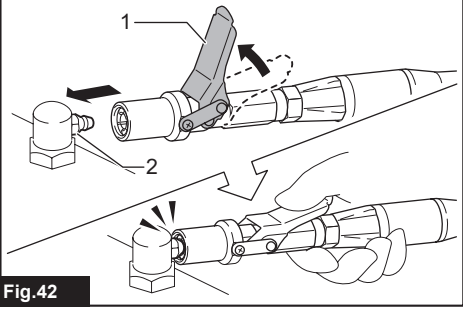
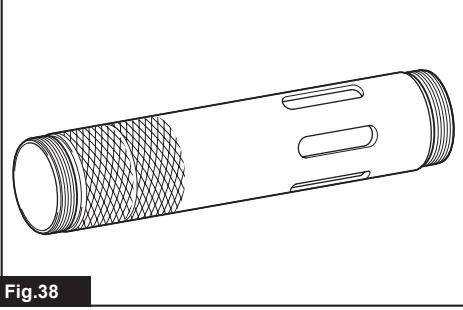
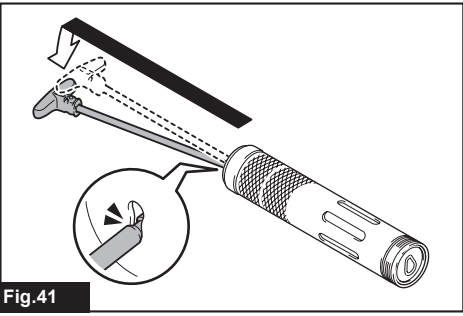
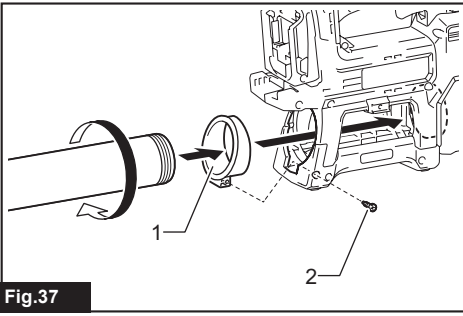

Fig.36



SPECIFICATIONS

Model:		DGP180
Rated voltage		D.C. 18 V
Grease capacity (with A-type barrel)	Cartridge	410 g
	Bulk	455 g
Grease capacity (with B-type barrel)	Cartridge	450 g
	Bulk	570 g
Maximum operating pressure		69 MPa
Maximum flow rate	Slow speed mode	145 ml/min
	Auto speed mode	290 ml/min
Applicable grease type		NLGI No.0 - No.2
Hose length		1,200 mm
Overall length	With A-type barrel	411 mm
	With B-type barrel	449 mm
Net weight		4.8 - 6.1 kg

NOTE: The barrel type (A-type or B-type) varies depending on the country.

- Due to our continuing program of research and development, the specifications herein are subject to change without notice.
- Specifications and battery cartridge may differ from country to country.
- The net weight value includes the lightest and heaviest combination of the attachment(s) for normal and safe use and battery cartridge(s) which are specified in the instruction manual.

Applicable battery cartridge and charger

Battery cartridge	BL1815N / BL1820B / BL1830B / BL1840B / BL1850B / BL1860B
Charger	DC18RC / DC18RD / DC18RE / DC18SD / DC18SE / DC18SF / DC18SH / DC18WC

- Some of the battery cartridges and chargers listed above may not be available depending on your region of residence.

⚠WARNING: Only use the battery cartridges and chargers listed above. Use of any other battery cartridges and chargers may cause injury and/or fire.

Intended use

This tool is intended for dispensing grease.

Noise

The typical A-weighted noise level determined according to EN62841-1:

Sound pressure level (L_{pA}): 79 dB (A)

Uncertainty (K): 3 dB (A)

The noise level under working may exceed 80 dB (A).

NOTE: The declared noise emission value(s) has been measured in accordance with a standard test method and may be used for comparing one tool with another.

NOTE: The declared noise emission value(s) can also be used in a preliminary assessment of exposure.

⚠WARNING: Wear ear protection.

⚠WARNING: The noise emission during actual use of the power tool can differ from the declared total value(s) depending on the ways in which the tool is used.

⚠WARNING: Be sure to identify safety measures to protect the operator that are based on an estimation of exposure in the actual conditions of use (taking account of all parts of the operating cycle such as the times when the tool is switched off and when it is running idle in addition to the trigger time).

Vibration

The continuous vibration total value (tri-axial vector sum) determined according to EN62841-1:

Work mode: Grease pressure

Vibration emission (a_{hv}): 1.0 m/s²

Uncertainty (K): 1.5 m/s²

NOTE: The declared vibration total value(s) has been measured in accordance with a standard test method and may be used for comparing one tool with another.

NOTE: The declared vibration total value(s) can also be used in a preliminary assessment of exposure.

⚠WARNING: The vibration emission during actual use of the power tool can differ from the declared total value(s) depending on the ways in which the tool is used.

⚠WARNING: Be sure to identify safety measures to protect the operator that are based on an estimation of exposure in the actual conditions of use (taking account of all parts of the operating cycle such as the times when the tool is switched off and when it is running idle in addition to the trigger time).

The following shows the mean values of the peak amplitude of the acceleration from repeated shock vibrations, p_F , with corresponding uncertainty (K) determined according to EN62841-1.

Work mode: Grease pressure

p_F : 43 m/s²

Uncertainty (K) : 24 m/s²

NOTE: These declared values should not be used to determine hand arm vibration exposure.

Declarations of Conformity

For European countries only

The EU Declaration of Conformity can be accessed from the following URL.



https://support.makita.biz/doc/doc_index.html

For the UK

Annex A to this instruction manual or in digital format using the above URL.

SAFETY WARNINGS

General power tool safety warnings

⚠WARNING Read all safety warnings, instructions, illustrations and specifications provided with this power tool. Failure to follow all instructions listed below may result in electric shock, fire and/or serious injury.

Save all warnings and instructions for future reference.

The term "power tool" in the warnings refers to your mains-operated (corded) power tool or battery-operated (cordless) power tool.

Cordless grease gun safety warnings

1. **Hold the tool firmly.**
2. **Do not operate the tool near flame.** The grease may be flammable.
3. **Use only grease that meets the specifications stated in this instruction manual.** Installing a different type of grease or any materials other than grease may cause failure.
4. **Do not install any materials other than grease, such as oil.** The tool may be damaged, which may cause the material to leak forcefully and cause an injury.
5. **Do not carry the tool by the flexible hose or the rod handle.** The hose may be damaged, and the tool may fall and cause an injury.
6. **Before each use, check the flexible hose for bends or wear, and the tool for any damaged parts. Do not use the tool if the hose and/or tool are damaged.** Part of the tool and hose may be damaged or may rupture under high pressure. If a part ruptures, grease may get into the skin or eyes and cause serious injury or infection. Do not consider the injury as simple and easy. Seek medical attention immediately.
7. **Make sure the rod is secured firmly.** The rod may move accidentally and cause a pinching.
8. **Read and follow the instructions of grease manufacture before usage.**
9. **Keep hands and clothes away from the rod of the rod handle.** Otherwise your finger or clothes may be pinched.
10. **Wipe off grease adhering to the tool.** Otherwise the grease may cause slipping and result in an injury.
11. **Do not bend the flexible hose forcibly or stamp it.** Doing so may cause a breakage or deformation of the hose.
12. **Do not point the adapter at anyone in the vicinity.**
13. **Use only the flexible hose, adapter and attachment specified by Makita.** Use of any other hose, adapter and attachment may cause an injury.
14. **The grease gun may generate high pressure. Wear thick leather gloves and protective goggles when using the tool.** Grease may leak forcefully and cause an injury.
15. **Do not remove the guards from the flexible hose.** The guards prevent the hose from kinks. Removing the guards may cause the hose to be damaged, which may cause grease to leak forcefully and cause an injury.
16. **Use the angle adapter (optional accessory), when working in tight spaces where the flexible hose must be bent sharply.** Operating the tool with the flexible hose bent sharply may damage or deform the hose, resulting in injury.
17. **If the tool is accidentally dropped, perform an inspection to make sure that the tool and attachments have no damage, crack, or deformation.** Damage, cracks, or deformation may cause injuries.
18. **Take care to store this tool so that dirt and**

dust do not enter the tool. If dirt or dust enters the tool, the tool may break down, or the dirt may get mixed into the grease, which leads to malfunction of the mating parts.

If you notice any problems or abnormalities, stop using the tool immediately and contact your local Makita Service Center.

SAVE THESE INSTRUCTIONS.

Important safety instructions for battery cartridge

1. **Before using battery cartridge, read all instructions and cautionary markings on (1) battery charger, (2) battery, and (3) product using battery.**
2. **Do not disassemble or tamper with the battery cartridge.** It may result in a fire, excessive heat, or explosion.
3. **If operating time has become excessively shorter, stop operating immediately.** It may result in a risk of overheating, possible burns and even an explosion.
4. **If electrolyte gets into your eyes, rinse them out with clear water and seek medical attention right away.** It may result in loss of your eyesight.
5. **Do not short the battery cartridge:**
 - (1) **Do not touch the terminals with any conductive material.**
 - (2) **Avoid storing battery cartridge in a container with other metal objects such as nails, coins, etc.**
 - (3) **Do not expose battery cartridge to water or rain.**

A battery short can cause a large current flow, overheating, possible burns and even a breakdown.

6. **Do not store and use the tool and battery cartridge in locations where the temperature may reach or exceed 50 °C (122 °F).**
7. **Do not incinerate the battery cartridge even if it is severely damaged or is completely worn out.** The battery cartridge can explode in a fire.
8. **Do not nail, cut, crush, throw, drop the battery cartridge, or hit against a hard object to the battery cartridge.** Such conduct may result in a fire, excessive heat, or explosion.
9. **Do not use a damaged battery.**
10. **The contained lithium-ion batteries are subject to the Dangerous Goods Legislation requirements.**

For commercial transports e.g. by third parties, forwarding agents, special requirement on packaging and labeling must be observed. For preparation of the item being shipped, consulting an expert for hazardous material is required. Please also observe possibly more detailed national regulations.

Tape or mask off open contacts and pack up the battery in such a manner that it cannot move around in the packaging.
11. **When disposing the battery cartridge, remove it from the tool and dispose of it in a safe**

place. Follow your local regulations relating to disposal of battery.

12. **Use the batteries only with the products specified by Makita.** Installing the batteries to non-compliant products may result in a fire, excessive heat, explosion, or leak of electrolyte.
13. **If the tool is not used for a long period of time, the battery must be removed from the tool.**
14. **During and after use, the battery cartridge may take on heat which can cause burns or low temperature burns. Pay attention to the handling of hot battery cartridges.**
15. **Do not touch the terminal of the tool immediately after use as it may get hot enough to cause burns.**
16. **Do not allow chips, dust, or soil stuck into the terminals, holes, and grooves of the battery cartridge.** It may cause heating, catching fire, burst and malfunction of the tool or battery cartridge, resulting in burns or personal injury.
17. **Unless the tool supports the use near high-voltage electrical power lines, do not use the battery cartridge near high-voltage electrical power lines.** It may result in a malfunction or breakdown of the tool or battery cartridge.
18. **Keep the battery away from children.**

SAVE THESE INSTRUCTIONS.

⚠ CAUTION: Only use genuine Makita batteries. Use of non-genuine Makita batteries, or batteries that have been altered, may result in the battery bursting causing fires, personal injury and damage. It will also void the Makita warranty for the Makita tool and charger.

NOTICE: Makita is not responsible for any accidents resulting from the use of non-genuine Makita batteries or batteries that have been modified. Genuine Makita batteries have been rigorously evaluated for compatibility with Makita tools and chargers, in line with applicable legislation and safety standards.

Tips for maintaining maximum battery life

1. **Charge the battery cartridge before completely discharged. Always stop tool operation and charge the battery cartridge when you notice less tool power.**
2. **Never recharge a fully charged battery cartridge. Overcharging shortens the battery service life.**
3. **Charge the battery cartridge with room temperature at 10 °C - 40 °C (50 °F - 104 °F). Let a hot battery cartridge cool down before charging it.**
4. **When not using the battery cartridge, remove it from the tool or the charger.**
5. **Charge the battery cartridge if you do not use it for a long period (more than six months).**

PARTS DESCRIPTION

► Fig.1

1	Switch trigger	2	Lock button	3	Lamp switch
4	Lamp	5	Trigger-lock button	6	Speed mode changing knob
7	Air drain	8	Filler port plug	9	Flexible hose
10	Adapter	11	Strap hole	12	Battery cartridge
13	Barrel	14	Rod handle	15	Hose holder
16	Pressure relief valve	17	Shoulder strap	18	Guard

FUNCTIONAL DESCRIPTION

⚠ CAUTION: Always be sure that the tool is switched off and the battery cartridge is removed before adjusting or checking function on the tool.

Installing or removing battery cartridge

⚠ CAUTION: Always switch off the tool before installing or removing of the battery cartridge.

⚠ CAUTION: Hold the tool and the battery cartridge firmly when installing or removing battery cartridge. Failure to hold the tool and the battery cartridge firmly may cause them to slip off your hands and result in damage to the tool and battery cartridge and a personal injury.

To install the battery cartridge, align the tongue on the battery cartridge with the groove in the housing and slip it into place. Insert it all the way until it locks in place with a little click. If you can see the red indicator as shown in the figure, it is not locked completely.

To remove the battery cartridge, slide it from the tool while sliding the button on the front of the cartridge.

► Fig.2: 1. Red indicator 2. Button 3. Battery cartridge

⚠ CAUTION: Always install the battery cartridge fully until the red indicator cannot be seen. If not, it may accidentally fall out of the tool, causing injury to you or someone around you.

⚠ CAUTION: Do not install the battery cartridge forcibly. If the cartridge does not slide in easily, it is not being inserted correctly.

Tool / battery protection system

The tool is equipped with a tool/battery protection system. This system automatically cuts off power to the motor to extend tool and battery life. The tool will automatically stop during operation if the tool or battery is placed under one of the following conditions:

Overload protection

When the tool/battery is operated in a manner that causes it to draw an abnormally high current, the tool automatically stops without any indication. In this situation, turn the tool off and stop the application that caused the tool to become overloaded. Then turn the tool on to restart.

Overheat protection

When the tool or battery is overheated, the tool stops automatically and the lamp blinks. In this case, let the tool and battery cool before turning the tool on again.

Overdischarge protection

When the battery capacity is not enough, the tool stops automatically. In this case, remove the battery from the tool and charge the battery.

NOTE: The protection system may become more likely to work depending on the ambient temperature or the type and condition of grease.

Protections against other causes

The protection system is also designed for other causes that could damage the tool and allows the tool to stop automatically. Take all the following steps to clear the causes when the tool has been brought to a temporary halt or stop in operation.

1. Turn the tool off, and then turn it on again to restart.
2. Charge the battery(ies) or replace it/them with recharged battery(ies).
3. Let the tool and battery(ies) cool down.

If no improvement can be found by restoring the protection system, then contact your local Makita Service Center.

Indicating the remaining battery capacity

Only for battery cartridges with the indicator

Press the check button on the battery cartridge to indicate the remaining battery capacity. The indicator lamps light up for a few seconds.

► Fig.3: 1. Indicator lamps 2. Check button

Indicator lamps			Remaining capacity
Lighted	Off	Blinking	
■	□	▧	75% to 100%
■ ■ ■ ■			
■ ■ ■ □			50% to 75%
■ ■ □ □			25% to 50%
■ □ □ □			0% to 25%
▧ □ □ □			Charge the battery.
■ ■ □ □			The battery may have malfunctioned.
□ □ ■ ■	↑ ↓		

NOTE: Depending on the conditions of use and the ambient temperature, the indication may differ slightly from the actual capacity.

NOTE: The first (far left) indicator lamp will blink when the battery protection system works.

Switch action

CAUTION: Before installing the battery cartridge into the tool, always check to see that the switch trigger actuates properly and returns to the "OFF" position when released.

CAUTION: When not operating the tool, depress the trigger-lock button from "A" side to lock the switch trigger in the OFF position.

To prevent the switch trigger from accidentally pulled, the trigger-lock button is provided.

To start the tool, depress the trigger-lock button from "B" side and pull the switch trigger.

Tool speed is increased by increasing pressure on the switch trigger. Release the switch trigger to stop. After use, always press in the trigger-lock button from "A" side.

For continuous operation, pull the switch trigger and then push in the lock button. To stop the tool from the locked position, pull the switch trigger fully to unlock.

► **Fig.4:** 1. Switch trigger 2. Lock button 3. Trigger-lock button

Lighting up the front lamp

CAUTION: Do not look into the light or look directly at the light source.

Press the lamp switch to light up the lamp. Press the lamp switch again to turn off the lamp. When the tool is left without any operation for about 60 seconds with the motor stopped, the lamp goes out.

► **Fig.5:** 1. Lamp 2. Lamp switch

NOTICE: Use a dry cloth to wipe the dirt off the lens of the lamp. Be careful not to scratch the lens of the lamp, or it may lower the illumination.

Selecting the speed mode

NOTICE: Change the speed mode only after the tool comes to a complete stop.

The tool employs the speed mode changing knob. Turn the knob so that the arrow on the knob points toward one of the two modes below;

1	Slow speed mode: Dispense grease at constant slow speed.
2	Auto speed mode: Apply grease while varying the flow rate automatically according to pressure of supply destination.

► **Fig.6:** 1. Speed mode changing knob

Pressure relief valve

When the internal pressure in the tool exceeds a certain level, grease comes out from the pressure relief valve to lower the internal pressure.

► **Fig.7:** 1. Pressure relief valve

CAUTION: Do not remove or make any adjustment to the pressure relief valve.

CAUTION: Do not remove the cover of pressure relief valve. Otherwise grease may spout out of the pressure relief valve and get into eyes.

ASSEMBLY

CAUTION: Always be sure that the tool is switched off and the battery cartridge is removed before carrying out any work on the tool.

Removing or installing barrel

To remove the barrel, screw it as illustrated.

► **Fig.8:** 1. Barrel

To install the barrel, insert it into the tool then screw in reverse.

► **Fig.9:** 1. Barrel

Rod handle

NOTICE: Do not pull the rod handle with valve for air drain fastened while the barrel installed in the tool. Make sure the valve for air drain is loosened. Failure to do so may cause malfunction.

Pull the rod handle when installing grease in the barrel.

► **Fig.10:** 1. Rod handle 2. Rod

To lock the rod handle fully pulled, pull the rod handle until the groove on the rod can be seen, and then hook the groove onto the slot. To unlock the rod handle, unhook the groove so the rod moves forward.

► Fig.11: 1. Groove 2. Slot

CAUTION: Make sure the rod handle is locked firmly. Otherwise it may be unlocked accidentally and cause a pinching.

Hose holder

The hose holder can be attached to either side of the tool with the screw.

► Fig.12: 1. Hose holder 2. Screw

Shoulder strap

WARNING: Never use the strap hole for lanyard (tether strap). Doing so may result in serious injury because the strap hole is not intended for a safety device for fall prevention.

WARNING: When carrying the tool, keep holding the tool even if when using the shoulder strap. Carrying the tool using only the shoulder strap makes it unstable. The shoulder strap may come off or the tool hit other objects and cause injury.

Attach the hooks of the shoulder strap onto the mounts of the strap holes as shown in the figure.

► Fig.13: 1. Shoulder strap 2. Hook 3. Mount

OPERATION

Grease supply

NOTICE: When using the barrel with the old grease remains, remove the barrel and purge the old grease according to the section for purge of grease.

There are following ways to provide grease:

Installing grease cartridge (commercially-bought) in the barrel

NOTICE: (For A-type barrel only)

Use the grease cartridge whose brim can be hooked on the end surface of the barrel.

NOTICE: (For B-type/C-type barrel only)

Use the grease cartridge whose brim can be hooked on the inside step of the barrel.

1. Loosen the valve for air drain.
► Fig.14: 1. Valve
2. Fully pull the rod handle and lock it.
► Fig.15: 1. Groove 2. Rod 3. Rod handle
3. Remove the barrel from the tool.
► Fig.16: 1. Barrel
4. Remove the plastic cap of the grease cartridge and insert the grease cartridge into the barrel.
► Fig.17: 1. Grease cartridge (commercially-bought)
2. Pull tab

5. Remove the pull tab of the grease cartridge then install the barrel to the tool.

If there is a gap between the brim of the grease cartridge and the barrel, screw the barrel into the tool while pushing the barrel forward.

► Fig.18

6. Release the rod handle.

► Fig.19

7. Eject the air that remains in the flow path of the grease.

► Fig.20

8. Fasten the valve for air drain when you see the grease coming out of the hole.

► Fig.21

NOTE: If the tool cannot pour grease accurately, air may remain in the flow path of the grease. Loosen the valve for air drain and eject the air. (Refer to the section for ejection of air.)

Filling grease in the barrel from a bulk container (commercially-bought)

1. Loosen the valve for air drain.
 2. Fully pull the rod handle and lock it.
 3. Remove the barrel from the tool.
- Unlock the rod handle and move the rod forward gently.
4. Dip the tip of the barrel in the grease and then pull the rod handle. The grease is pumped up into the barrel.

► Fig.22: 1. Bulk container (commercially-bought)

5. Fully pull the rod handle and lock it.

► Fig.23

6. Install the barrel to the tool and then unlock the rod handle.

7. Eject the air that remains in the flow path of the grease.

8. Fasten the valve for air drain when you see the grease coming out of the hole.

NOTICE: When locking the rod handle, make sure the rod handle is locked firmly. Otherwise the rod handle get unlocked unintentionally, the grease comes out from the barrel.

NOTE: (For B-type/C-type barrel only)

The amount of grease filling should be below the screw groove line. Otherwise grease will overflow when installing the barrel to the tool.

► Fig.24: 1. Barrel (B-type/C-type) 2. Screw groove
3. Grease

NOTE: If the tool cannot pour grease accurately, air may remain in the flow path of the grease. Loosen the valve for air drain and eject the air. (Refer to the section for ejection of air.)

You can also fill grease into the barrel using a filler pump (commercially-bought) attached to the bulk container.

1. Remove the barrel from the tool.
2. Wrap thread seal tape around the thread part of the loader fitting (optional accessory or commercially-bought).
3. Remove the filler port plug. Attach a loader fitting to the filler port.
4. Install the barrel to the tool. (The rod handle is unlocked.)
5. Make sure that the valve for air drain is fastened.

Connect the loader fitting to the fitting of the filler pump.

► **Fig.25:** 1. Filler port plug 2. Filler port 3. Loader fitting (optional accessory or commercially-bought) 4. Filler pump (commercially-bought) 5. Fitting

6. Operate the filler pump. The rod of the rod handle will be pushed out as the barrel is filled with grease.

► **Fig.26**

7. Disconnect the loader fitting from the fitting of the filler pump.

8. Eject the air that remains in the flow path of the grease.

9. Fasten the valve for air drain when you see the grease coming out of the hole.

⚠ WARNING: Use a low-pressure loader fitting (NPT 1/8") only. Never use a high-pressure loader fitting otherwise it may damage the tool and cause a personal injury.

⚠ CAUTION: Hold the tool firmly when filling the grease by using a filler pump. The tool may fall and cause an injury.

NOTICE: Stop filling the grease when you see the groove on the rod. Otherwise the grease leakage may occur.

NOTE: If the tool cannot pour grease accurately, air may remain in the flow path of the grease. Loosen the valve for air drain and eject the air. (Refer to the section for ejection of air.)

Ejection of air

If air remains in the flow path of the grease, the tool cannot pour grease accurately. Eject the air before each use and also when the tool seems to work improperly due to air.

1. To eject air from inside of the tool, loosen the valve for air drain. Air comes out from the hole for air drain.
2. Fasten the valve when you see the grease coming out of the hole.

► **Fig.27:** 1. Valve

⚠ WARNING: Wear the protective goggles when ejecting the air.

⚠ CAUTION: Wipe off the grease that comes out from the air drain with a dry cloth or the like. Otherwise it may cause slipping and result in an injury.

Dispensing the grease

In the following cases, purge the old grease inside the tool before use;

- When using the tool for the first time or;
- When using different type of the grease from previous use.

With the new grease filled in the barrel, run the tool for a while until the old grease is pushed out from the adapter.

NOTICE: Do not connect the adapter to the grease nipple until the old grease is purged. If different kinds of grease are mixed, the performance of the grease may decline.

NOTE: The tool has been tested at the factory and small amount of the grease remains.

Perform the following procedure to dispense the grease.

⚠ CAUTION: Always check the speed mode before operation.

NOTICE: Before connecting the adapter to the grease nipple, always make sure that the tool dispenses grease properly.

NOTICE: Do not connect the adapter to the grease nipple forcibly.

1. Wipe the adapter and the grease nipple before connecting. Push the adapter straight at the grease nipple.
2. Pull the switch trigger to dispense the grease.

► **Fig.28**

3. When dispensing the grease is finished, remove the adapter from the grease nipple. Tilt the adapter slightly to release internal pressure and then remove the adapter from the grease nipple.

Wipe off the grease from the adapter and the grease nipple.

NOTICE: Do not leave the tool running even after the grease depleted. It may shorten the life of the tool.

NOTE: If the tool cannot pour grease accurately, air may remain in the flow path of the grease. Loosen the valve for air drain and eject the air. (Refer to the section for ejection of air.)

NOTE: If the internal pressure rises while the switch trigger is not fully pulled, the protection system works and the motor will stop even though the tool does not reach the maximum operating pressure. When injecting the grease at high pressure, pull the switch trigger fully.

NOTE: The tool stops automatically when the tool keep running for more than 6 minutes.

In the case that the tool does not pour grease accurately

If the tool cannot pour grease accurately, air may remain in the flow path of the grease. Eject the air

according to the following procedure.

1. Loosen the valve for air drain.
▶ **Fig.29:** 1. Valve
2. Eject the air that remains in the flow path of the grease.
▶ **Fig.30**
3. Fasten the valve for air drain when you see the grease coming out of the hole.
▶ **Fig.31**

MAINTENANCE

⚠ CAUTION: Always be sure that the tool is switched off and the battery cartridge is removed before attempting to perform inspection or maintenance.

NOTICE: Never use gasoline, benzine, thinner, alcohol or the like. Discoloration, deformation or cracks may result.

To maintain product SAFETY and RELIABILITY, repairs and any other maintenance or adjustment should be performed by Makita Authorized or Factory Service Centers, always using Makita replacement parts.

Purge of grease

When storing the tool or using the barrel in which the grease remains, remove the barrel and purge the old grease in the following procedure.

1. Loosen the valve for air drain.
2. Fully pull the rod handle and lock it.
3. Remove the barrel from the tool.
4. Unlock the rod handle. Keep holding the rod handle and slowly move the rod handle forward so the grease gets out of the barrel.

⚠ CAUTION: Do not take hand off from the rod handle. Otherwise the grease pops out vigorously.

NOTICE: Keep dust away from inside of the barrel. Dust may get clogged in the tool.

NOTICE: Clean the inside of the barrel once every three months.

OPTIONAL ACCESSORIES

⚠ CAUTION: These accessories or attachments are recommended for use with your Makita tool specified in this manual. The use of any other accessories or attachments might present a risk of injury to persons. Only use accessory or attachment for its stated purpose.

If you need any assistance for more details regarding

these accessories, ask your local Makita Service Center.

- Adapter
- Flexible hose
- Barrel
- Cartridge barrel
- Shoulder strap
- Lock on adapter
- Angle adapter
- Extension pipe
- Loader fitting
- Makita genuine battery and charger

NOTE: Some items in the list may be included in the tool package as standard accessories. They may differ from country to country.

Replacing of the adapter

Loosen and remove the old adapter with two wrenches as illustrated and then tighten the new adapter securely.
▶ **Fig.32**

NOTE: If grease leaks from the joint between the hose and the adapter, wrap thread seal tape around the thread part of the hose before connecting the adapter.

Replacing of the flexible hose

Loosen and remove the old flexible hose with a wrench as illustrated and then tighten the new flexible hose securely.
▶ **Fig.33**

⚠ CAUTION: Replace the rubber ring attached to the connection part of the new flexible hose at the same time. If you replace the flexible hose without the rubber ring or with the old rubber ring, grease may leak and cause an injury.

Changing the barrel

NOTE: The barrel type varies depending on the country.

NOTE: To install a barrel of different type, additional parts described below are required depending on the type of the barrel.

Changing the barrel from A-type to B-type/C-type

1. Remove A-type barrel.
2. Remove the screw and then the sleeve.
▶ **Fig.34:** 1. Sleeve 2. Screw
3. Insert the joint with the rubber packing while aligning the tab with the groove on the mounting part and then secure it with screws.
4. Install B-type/C-type barrel.
▶ **Fig.35:** 1. Joint 2. Rubber packing 3. Tab 4. Groove 5. Screw

Changing the barrel from B-type/C-type to A-type

1. Remove B-type/C-type barrel.
2. Unscrew and remove the joint.
▶ **Fig.36:** 1. Joint 2. Rubber packing 3. Screw
3. Insert the sleeve into the tool housing, then secure it with a screw.
4. Install A-type barrel.
▶ **Fig.37:** 1. Sleeve 2. Screw

Cartridge barrel

You can see the grease cartridge through the hole on the cartridge barrel.

▶ **Fig.38**

When using the cartridge barrel, transfer the piston parts from the corresponding barrel to the cartridge barrel.

▶ **Fig.39:** 1. Piston parts 2. Cartridge barrel

If it is hard to pull out the rod handle, follow the procedure below.

1. Insert the empty grease cartridge into the barrel.
▶ **Fig.40:** 1. Empty grease cartridge
2. Pull the rod handle and lock it.
▶ **Fig.41**
3. Remove the empty grease cartridge from the barrel.

Lock on adapter

CAUTION: Be careful not to pinch the finger in the lock on adapter.

To connect the lock on adapter to the grease nipple, lift the thumb lever and slide the adapter onto the fitting. Push and hold the adapter to make firm engagement with the grease nipple fitting. Then press down the thumb lever to secure the connection.

▶ **Fig.42:** 1. Thumb lever 2. Grease nipple

To assemble the lock on adapter, refer to the section for replacing of the adapter.

Angle adapter

WARNING: Use the angle adapter, when working in tight spaces where the flexible hose must be bent sharply. Operating the tool with the flexible hose bent sharply may damage or deform the hose, resulting in injury.

When attaching the angle adapter, push the adapter of the tool straight to the angle adapter.

▶ **Fig.43:** 1. Angle adapter

NOTE: The angle adapter is recommended for grease injection at relatively low pressure such as replacement of old grease in joints or sliding parts of heavy machinery and vehicles.

TROUBLE SHOOTING

Before asking for repairs, conduct your own inspection first. If you find a problem that is not explained in the manual, do not attempt to dismantle the tool. Instead, ask Makita Authorized Service Centers, always using Makita replacement parts for repairs.

State of abnormality	Probable cause (malfunction)	Remedy
The tool does not pour grease	Air remains in the flow path of the grease.	To eject air from inside of the tool, loosen the valve for air drain.
	The valve for air drain is loose.	Fasten the valve for air drain.
	The grease consistency is high.	Use NLGI No.0 - No.2 grease.
	The grease is hard due to low ambient/storage temperature.	Warm grease before use.
	No grease inside of the tool.	Supply grease into the tool.
You cannot pull the rod handle.	The valve for air drain is fastened.	Loosen the valve for air drain.
Grease leaks from the adapter.	There is wear, damage or dust on the grease injection port (grease nipple).	Clean or replace the grease injection port (grease nipple).
	Adapter is worn out.	Replace the adapter.
Grease does not come out of the air drain valve when ejecting the air.	The air drain valve is not loose enough.	Loosen the air drain valve further.
	The grease is hard.	The air may have already been ejected. Fasten the valve for air drain, install the battery cartridge, and turn on the tool to check if the tool pour grease.