



Assembly Instructions

SEYCHELLES 3.5M ROUND CANTILEVER PARASOL

(13104194 – HAVANNAH) (13105194 – SILHOUETTE)

TOP TIPS:

- Please read these instructions carefully before assembly
- Aluminium is soft metal and over tightening may strip thread or break the part
- Please allow 45 minutes for assembly.
- Assembly will require 2 people
- Simply clean the umbrella canopy with a soft brush and mild detergent.
- Do not machine wash or machine dry.
- Do not iron.
- Air-dry the canopy thoroughly in an open position before storing for extended periods of time.

IMPORTANT INFORMATION:









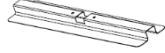

- **IMPORTANT!** Always close/put down the parasol when not in use. Do not use or assemble the parasol in heavy winds, rain, thunderstorms or if it's snowing. In these weather conditions, we recommend to fold down or disassemble the parasol. Disassemble by following the setup steps in this manual.
- **IMPORTANT!** The parasol must be secured in place using a parasol base. Make sure the ground is level and firm.
- **IMPORTANT!** If the crank gets too hard to turn, check if the rope has come off the pulley. If you continue to turn the crank, the rope or crank handle could break.
- **IMPORTANT!** Placing the parasol over or near a swimming pool can cause premature fading of the canopy.
- **IMPORTANT!** The cross section of the cantilever base is made from steel for added strength. To avoid any rust damage to your patio, we advise you lay a plastic membrane underneath.
- **WARNING:** To prevent damage to parasol, facing the canopy against the wind.
 - Do not assemble the parasol on sandy, muddy or loose soil.
 - Keep children and pets away while setting up the parasol.
 - Children must be supervised around the parasol.
 - This parasol is for outdoor use only.
 - Do not light any fires under or near the parasol!
 - This parasol is primarily intended to be used as a sunshade and not as wind protection.

For replacement or lost spare parts please go to <http://faq.hartmanuk.co.uk/spares/>

Should you have any queries about your furniture your first point of contact should be the retailer from whom you purchased your product.

For more information regarding maintenance of your furniture please visit <http://www.hartmanuk.com>

PARTS LIST

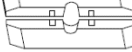
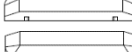
Component's					Component's				
Parts List	Parts Picture	Description	Q'ty	Component no.	Parts List	Parts Picture	Description	Q'ty	Component no.
A		Cross Base A	1	13104194A 13105194A	G		Parasol Frame with Canopy	1	13104194C 13105194C
B		Cross Base B	1	13104194B 13105194B	H		Solar Panel	1	2100025
C	 (M10X25)	Bolts	4	2100021	I		Cover	1	13104194D 13105194D
D	 (Ø10)	Washers	4	2100022	J		Battery Power	2	13104194E 13105194E
E		Wrench	1	2100023	K		USB cable	1	13104194F 13105194F
F		Crank Handle	2	2100024	L		Blow Molded Base 1	1	2100027
					M		Blow Molded Base 2	1	2100028

STEP BY STEP INSTRUCTIONS

Step 1

Place Cross Base(A) on a soft surface, line up notches and place Cross Base(B) over Cross Base(A).

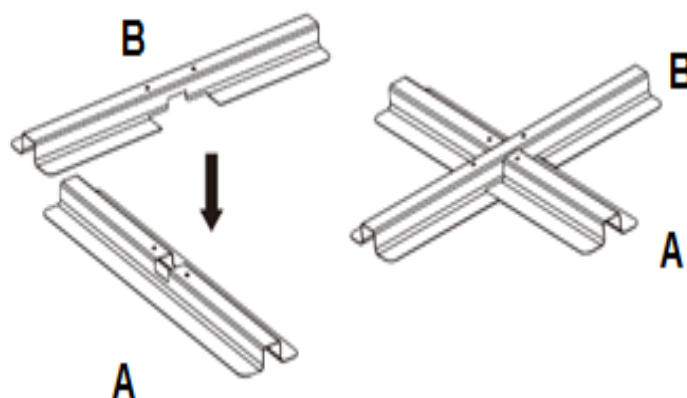

For replacement or lost spare parts please go to <http://faq.hartmanuk.co.uk/spares/>

Should you have any queries about your furniture your first point of contact should be the retailer from whom you purchased your product.

Step 2

Find the plug at the top of the parasol. Insert the plug into the socket under the Solar Panel (H) as shown.

Put the solar panel on the top of the parasol and hide the plug and wire inside the groove at the top of parasol. Then turn the solar panel clockwise.

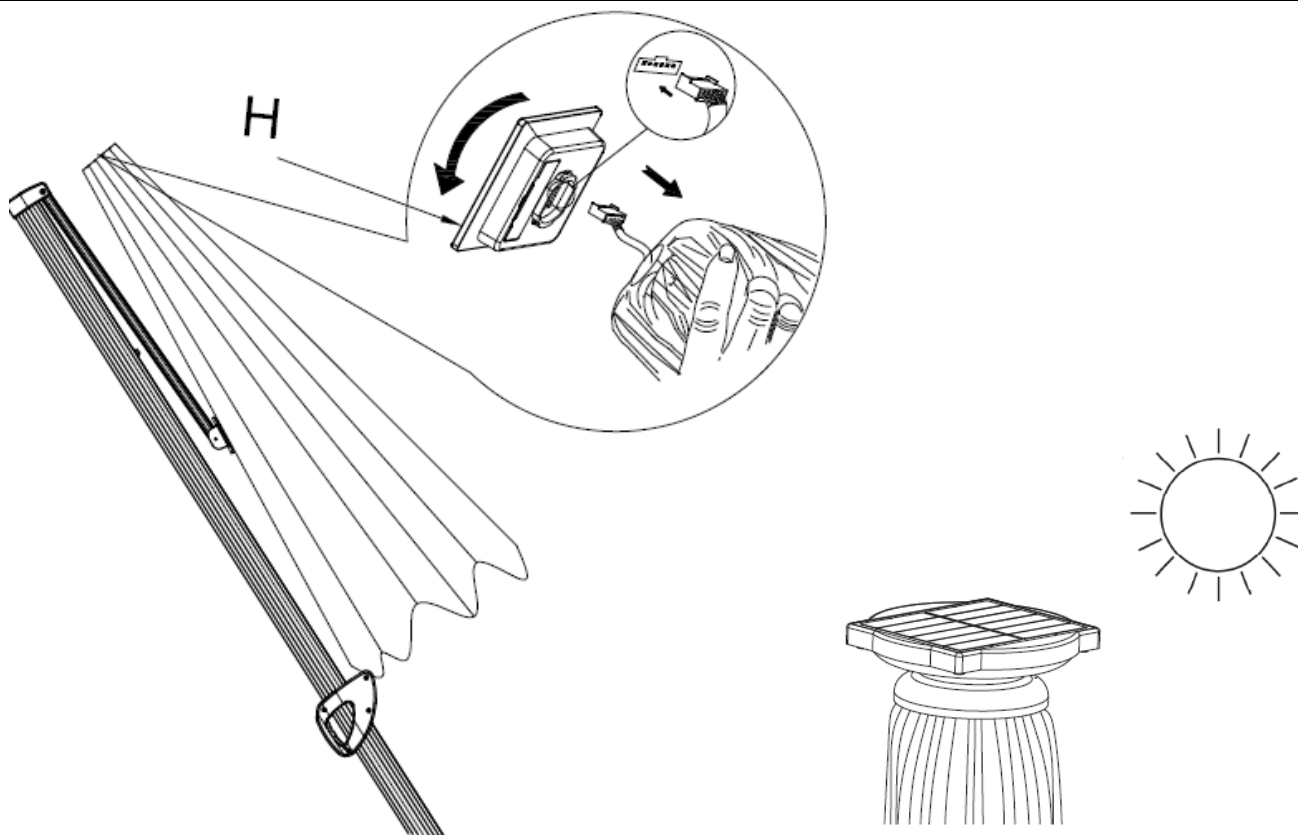

CAUTION:

YOU MUST CHARGE BATTERY BEFORE FIRST USE. Please note that battery can discharge if they are left unused or uncharged for a long period of time. Since there can be a six-month period between production and final customer purchase, we recommend you charge your solar parasol for at least 8 hours in direct sunlight before the first use. Failure to charge the battery will result in premature dimming of the lights in your new solar parasol. Make sure the light switch is in the off position when charging the solar panel. For everyday normal use, turn the light switch on at night when you want to use the solar light and turn off the switch after use. **MAKE SURE THE LIGHT SWITCH IS IN THE OFF POSITION IN THE DAYTIME FOR THE SOLAR PANEL TO RECHARGE THE BATTERY.**

For replacement or lost spare parts please go to <http://faq.hartmanuk.co.uk/spares/>

Should you have any queries about your furniture your first point of contact should be the retailer from whom you purchased your product.

Step 3

Attach the Parasol Frame with Canopy (G) to the base by using the bolts (C) and washers (D) (found in blister pack). Hand tighten first. Adjust the parasol (G) to be sure it is positioned correctly on the base. Finally tighten all bolts by using Wrench (E).

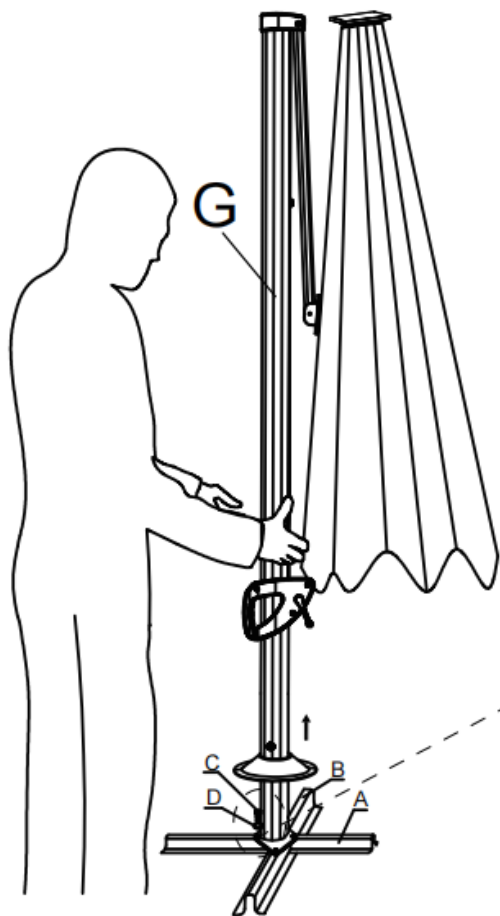

After the pole sit on the base, 1 person hold the pole and the other tighten the screw

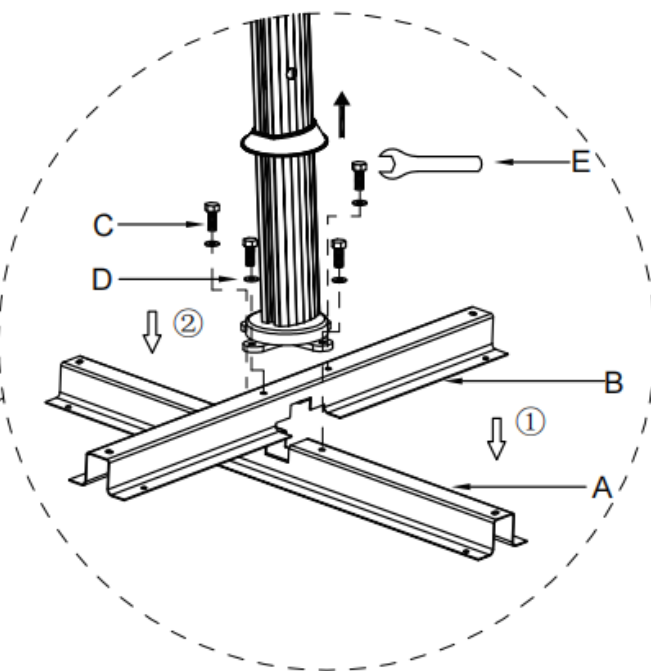

For replacement or lost spare parts please go to <http://faq.hartmanuk.co.uk/spares/>

Should you have any queries about your furniture your first point of contact should be the retailer from whom you purchased your product.

Step 6

Insert the Crank Handle (F).

To open the parasol, squeeze the Glide Handle and Lever clamp together and slide up or down the pole to achieve the desired tilting angle. Release the Lever clamp to lock into place. To open the canopy, turn the crank handle clockwise until the canopy is fully open.

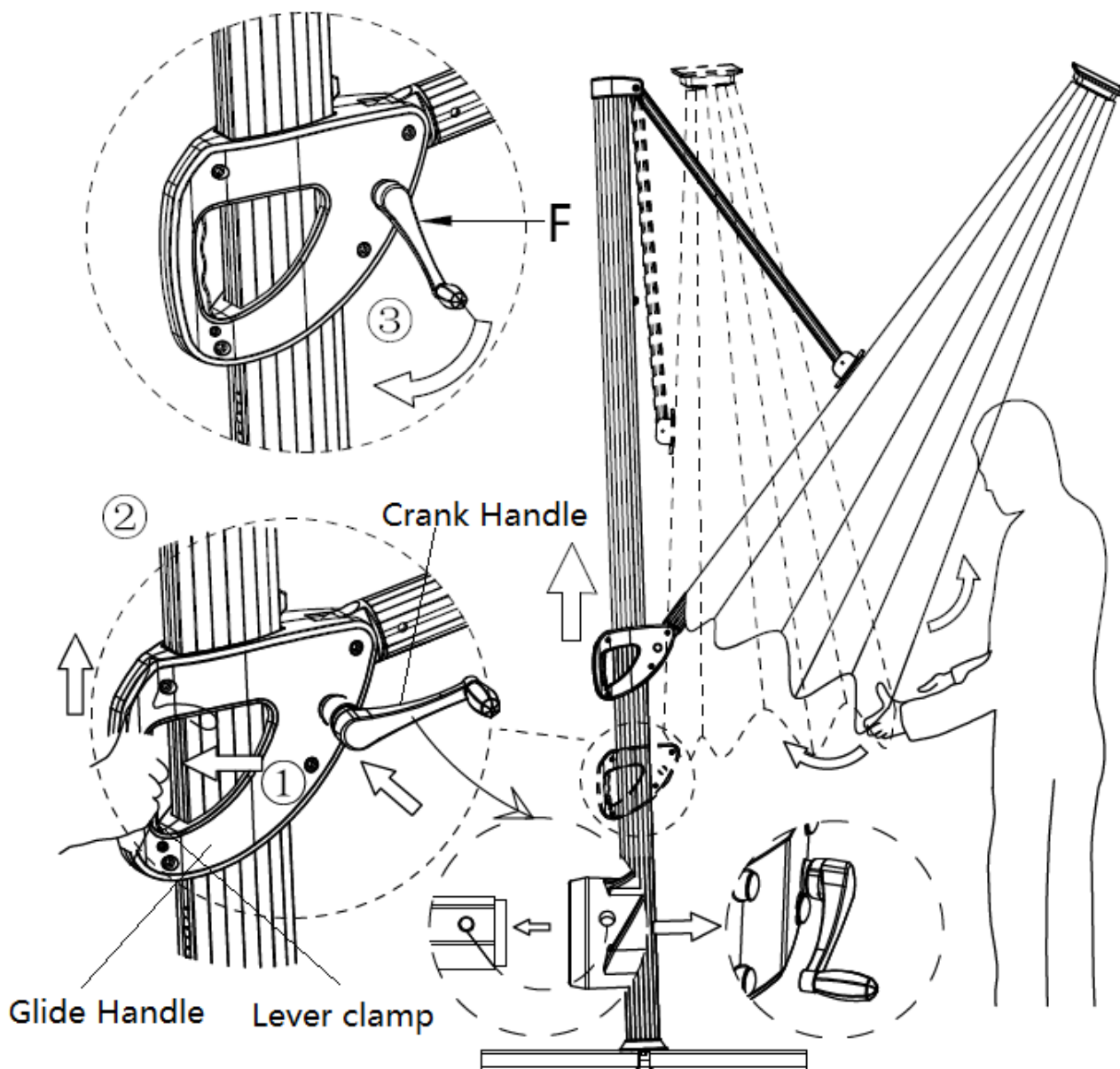

For replacement or lost spare parts please go to <http://faq.hartmanuk.co.uk/spares/>

Should you have any queries about your furniture your first point of contact should be the retailer from whom you purchased your product.

Step 7

Place the Battery Power (J) into the housing located on the arm of the glide handle. Then put the solar parasol in direct sunlight outdoors to charge the solar panel for at least 8 hours before the first use. (Parasol is equipped with 2 batteries. Remove the battery when it has drained. Replace battery once fully charged. When solar energy is insufficient. You can use the adapter to charge indoor.)

Press the light switch on the battery to turn on/off the solar lights.

Press the Bluetooth switch on the battery then hear a 'Beep' sound to turn the Bluetooth speakers on, and the Bluetooth light will begin to flash quickly. Be within 5 meters of the parasol to search from your device for the Bluetooth parasol. The Bluetooth parasol will be named " Umbrella BT-SPK". The Bluetooth light will flash slowly when it connects successfully.

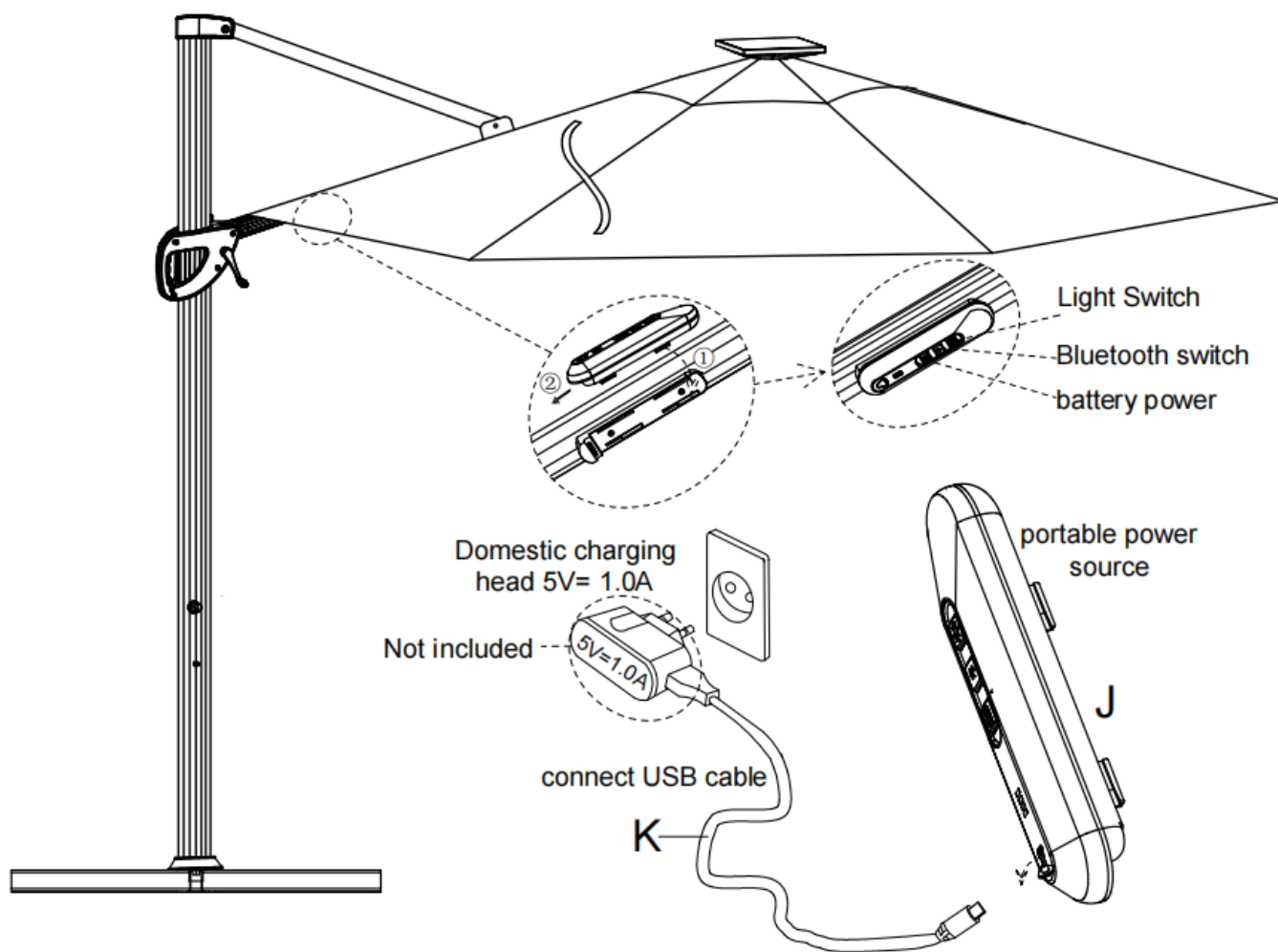

For replacement or lost spare parts please go to <http://faq.hartmanuk.co.uk/spares/>

Should you have any queries about your furniture your first point of contact should be the retailer from whom you purchased your product.

Step 8

To rotate parasol, insert the Crank Handle (F) into pole and turn to desired position.

The multiple position canopy can rotate 360° around the axis of the main pole to offer the shade on your expected area around the parasol.

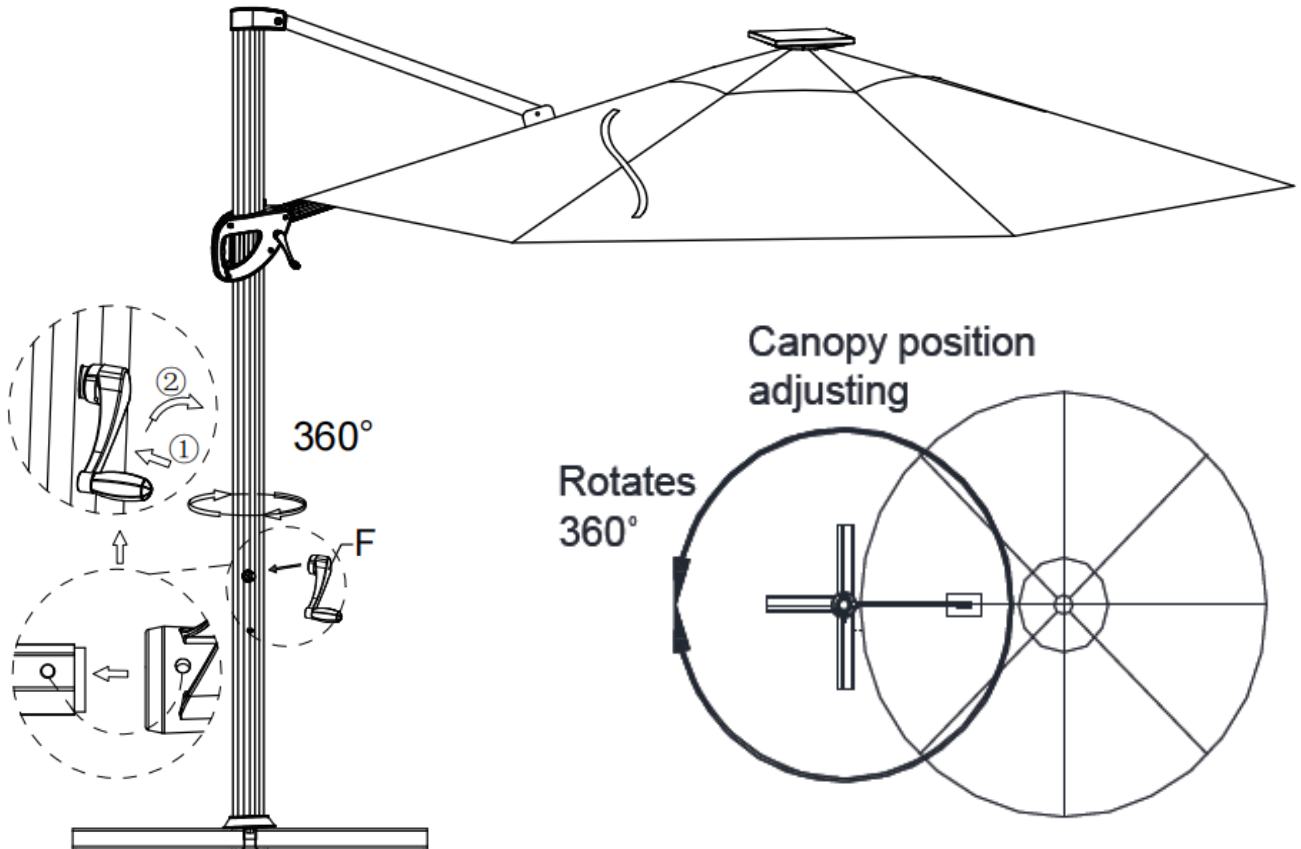

For replacement or lost spare parts please go to <http://faq.hartmanuk.co.uk/spares/>

Should you have any queries about your furniture your first point of contact should be the retailer from whom you purchased your product.

Step 9

Tilt the parasol to the desired angle.

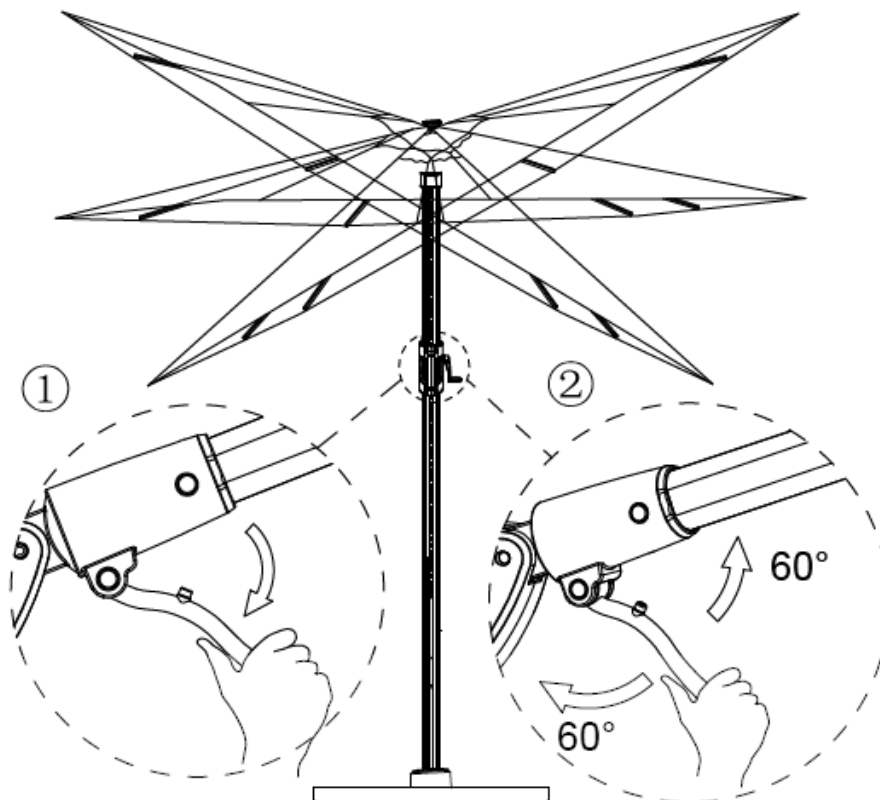
**Step 10**

To close the parasol, turn the Crank Handle counter clockwise until the canopy is fully closed. Squeeze the Glide Handle and Lever clamp together, then slide down the pole and release the grip to lock into place.

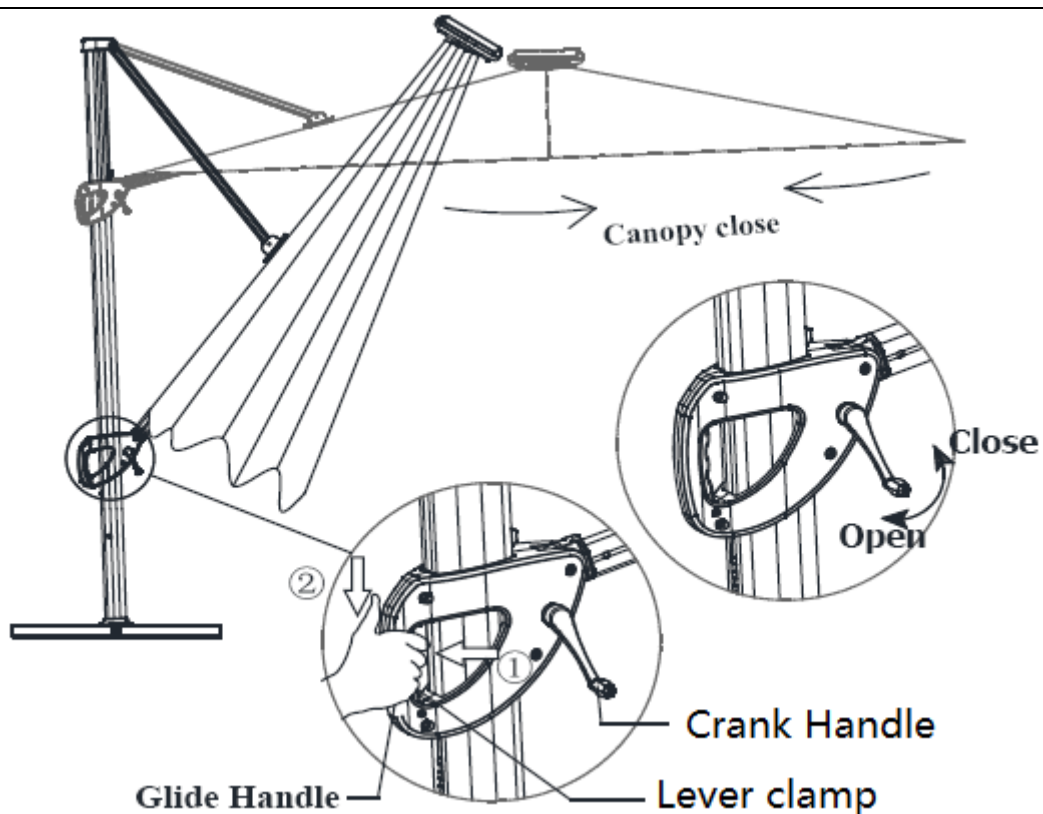

For replacement or lost spare parts please go to <http://faq.hartmanuk.co.uk/spares/>

Should you have any queries about your furniture your first point of contact should be the retailer from whom you purchased your product.

Step 11

Fasten the storage straps around the canopy.

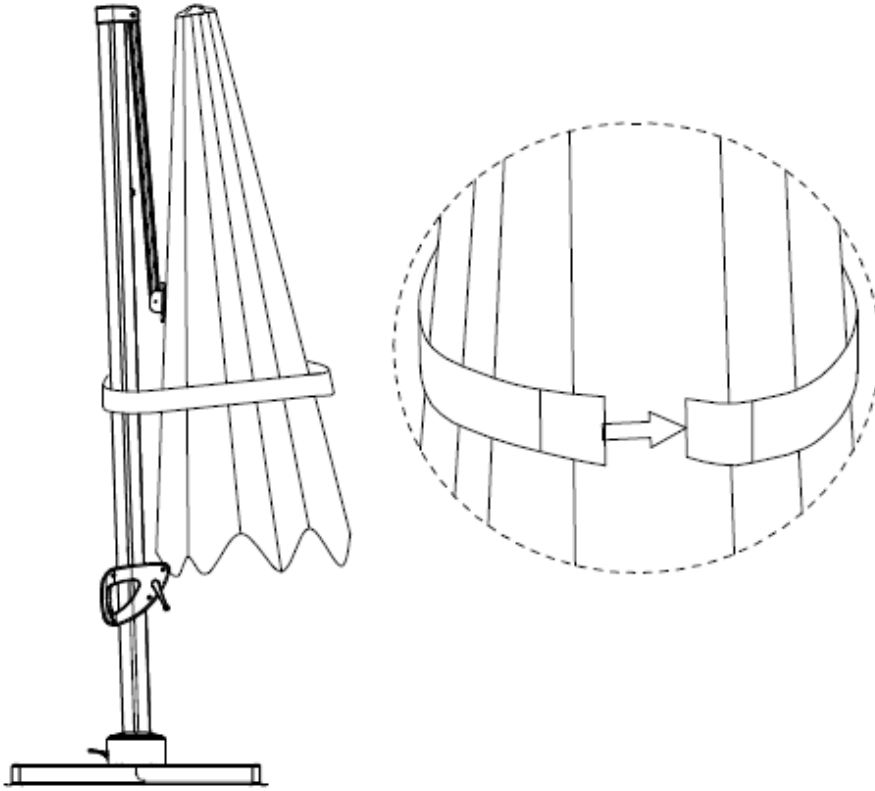

Step 12

Use Cover (I) when your parasol is not in use.

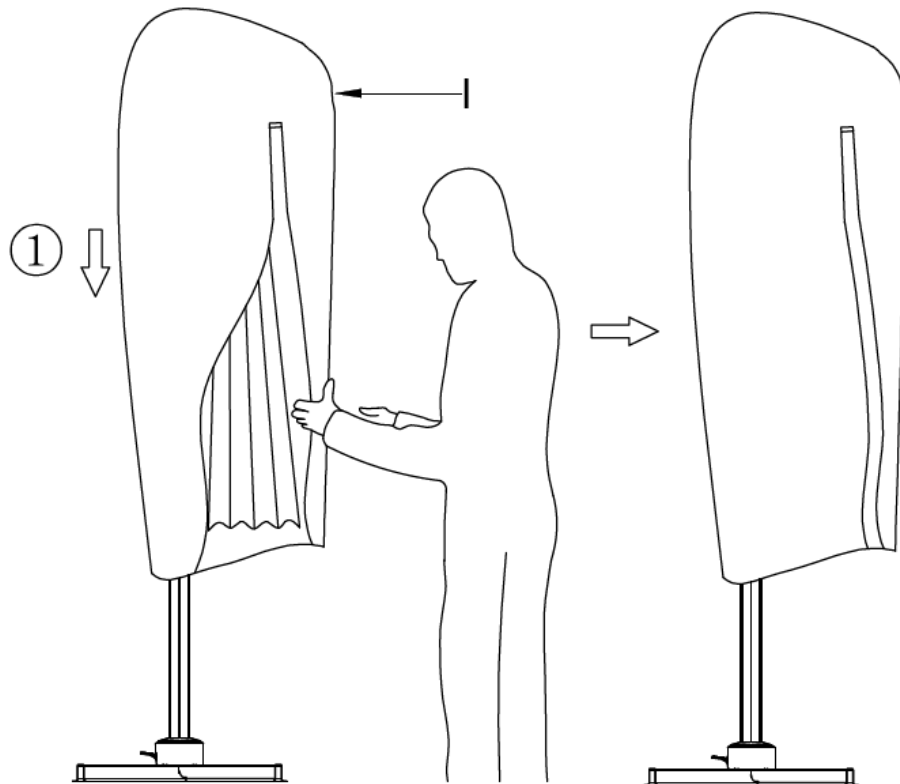

For replacement or lost spare parts please go to <http://faq.hartmanuk.co.uk/spares/>
Should you have any queries about your furniture your first point of contact should be the retailer from whom you purchased your product.

Battery Replacement

Step 1

Twist counterclockwise and remove the solar panel from the top of the parasol.

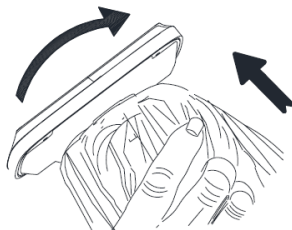

Step 2

Pull the plug out of the socket under the solar panel. Pull by holding the plug, not by pulling on the wires.

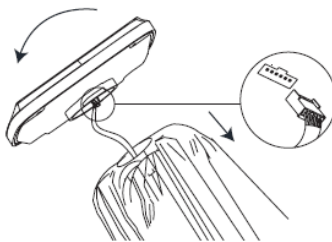

Step 3

Place the solar panel upside down on a flat, non-abrasive surface to avoid scratching. Remove all screws on the solar panel bottom case.

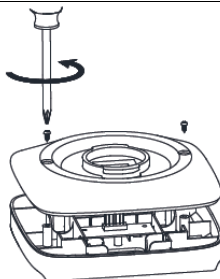

Step 4

Carefully open the bottom case and set aside. Replace the batteries, matching the +/- on battery case.

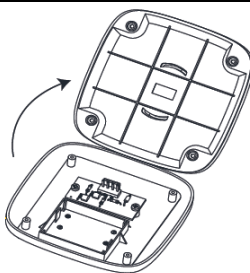

Step 5

Carefully put the bottom case back. Align the screw holes and replace the screws. Do not over tighten the screws.

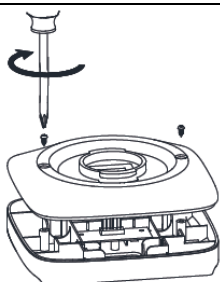

For replacement or lost spare parts please go to <http://faq.hartmanuk.co.uk/spares/>

Should you have any queries about your furniture your first point of contact should be the retailer from whom you purchased your product.