

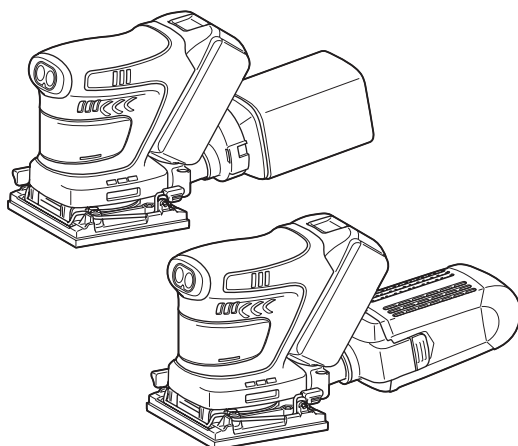

EN	Cordless Finishing Sander	INSTRUCTION MANUAL	7
FR	Ponceuse vibrante Sans Fil	MANUEL D'INSTRUCTIONS	14
DE	Akku-Schwingschleifer	BETRIEBSANLEITUNG	22
IT	Levigatrice di finitura a batteria	ISTRUZIONI PER L'USO	30
NL	Accuafwerkschuurmachine	GEBRUIKSAANWIJZING	38
ES	Lijadora de Acabado Inalámbrica	MANUAL DE INSTRUCCIONES	46
PT	Lixadeira Orbital a Bateria	MANUAL DE INSTRUÇÕES	54
DA	Akku svingsliber	BRUGSANVISNING	62
EL	Φορητό παλμικό τριβείο	ΕΓΧΕΙΡΙΔΙΟ ΟΔΗΓΙΩΝ	69
TR	Akülü Titreşimli Zımpara Makinası	KULLANMA KILAVUZU	77

DBO480
DBO481
DBO482



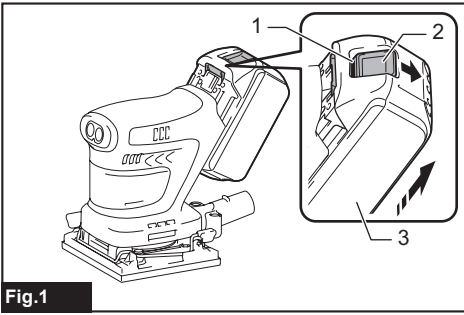

Fig.1

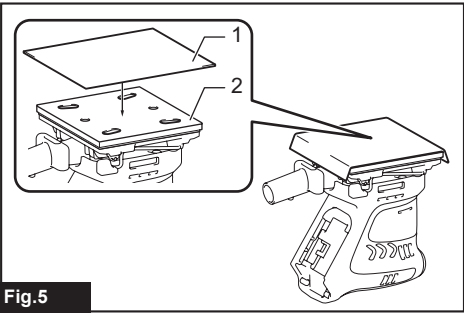

Fig.5

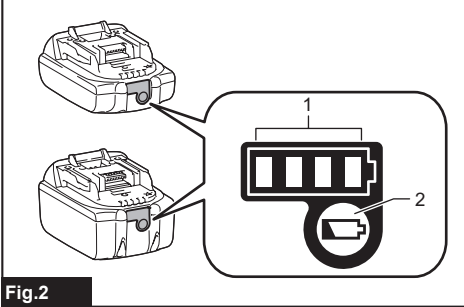

Fig.2

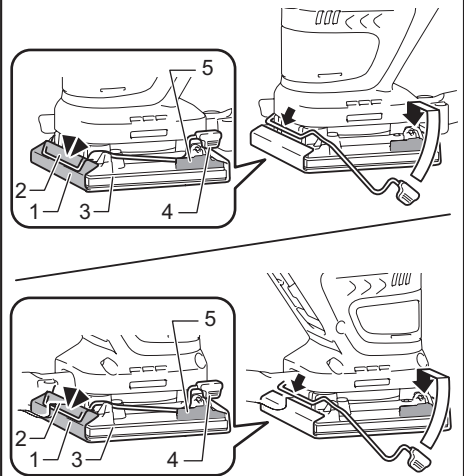

Fig.6

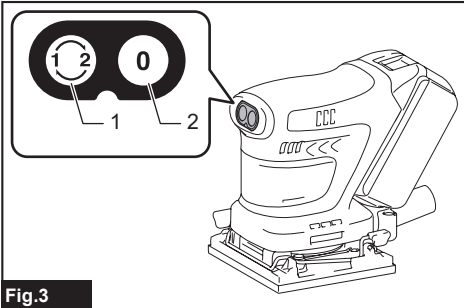

Fig.3

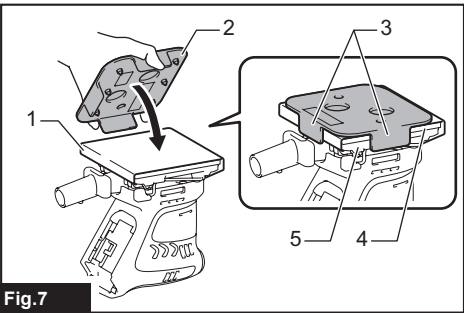

Fig.7

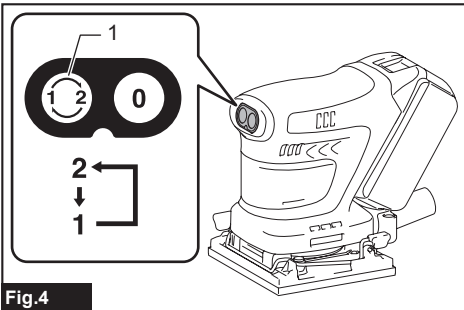

Fig.4

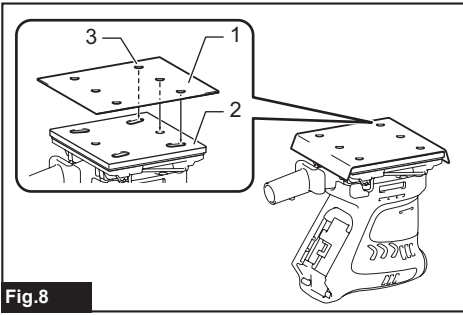

Fig.8

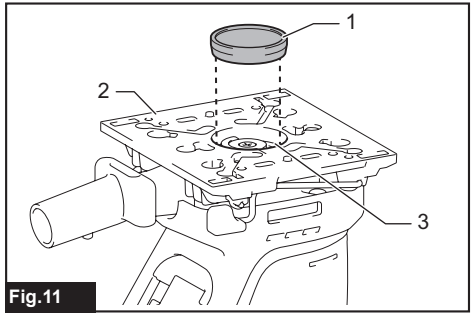

Fig.11

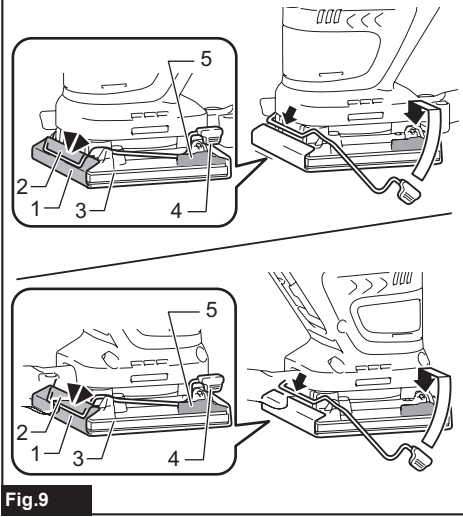

Fig.9

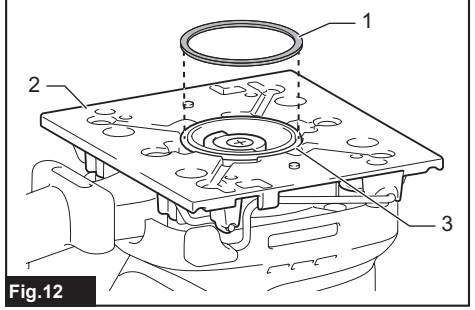

Fig.12

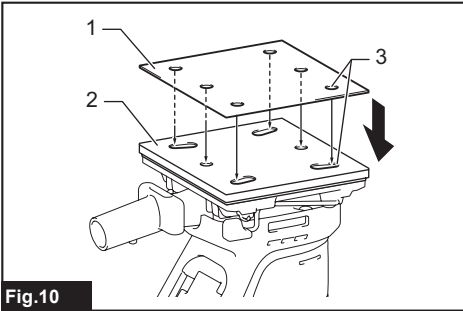

Fig.10

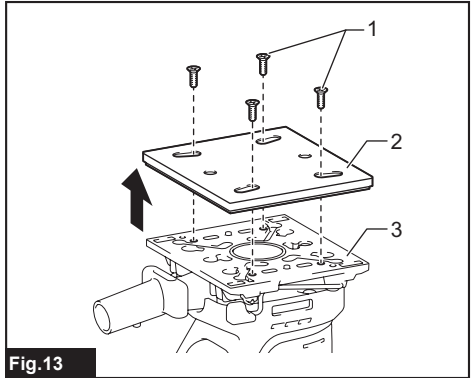

Fig.13

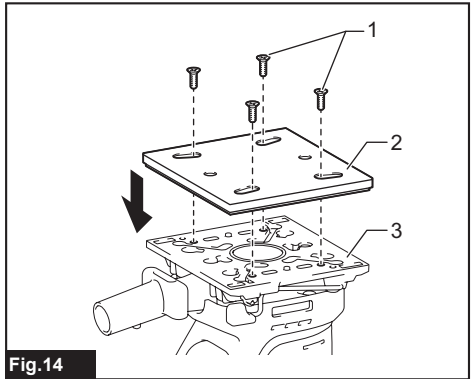
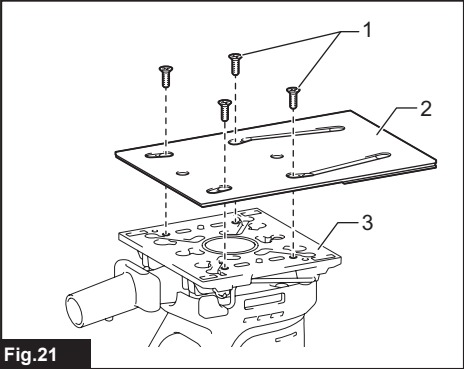
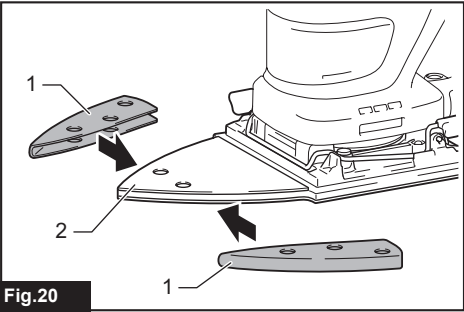
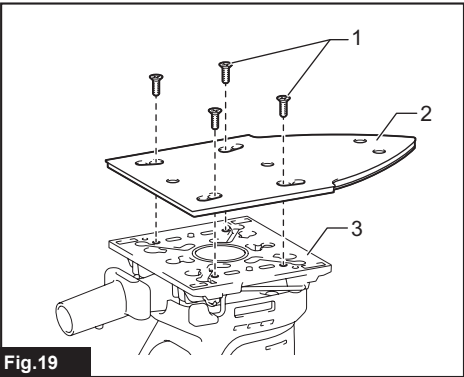
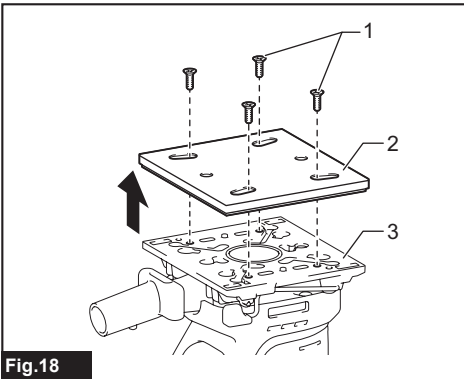
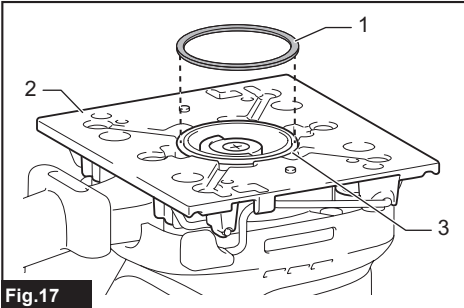
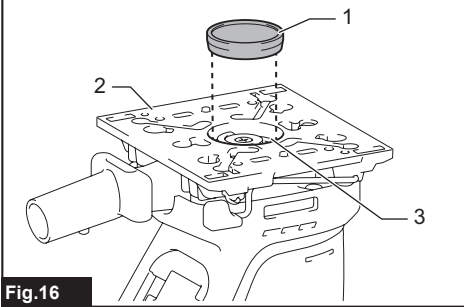
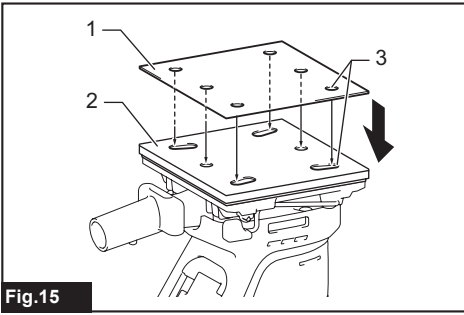

Fig.14



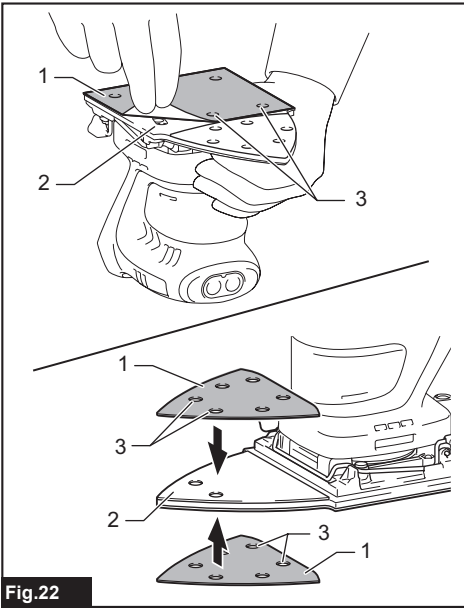

Fig.22

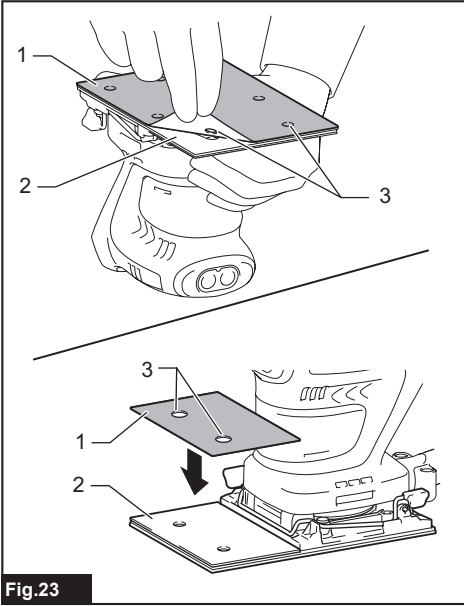

Fig.23

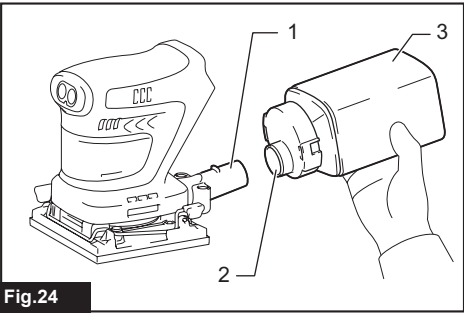

Fig.24

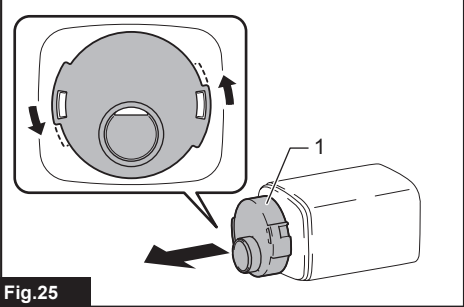

Fig.25

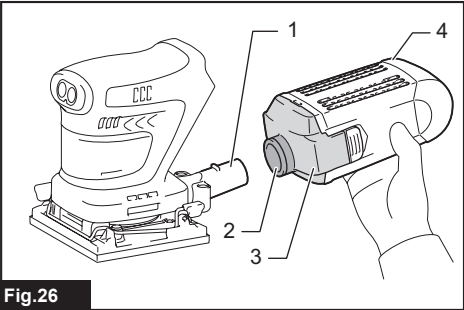

Fig.26

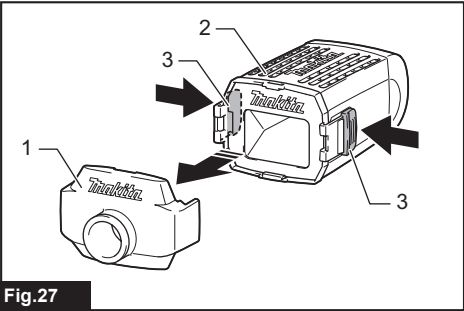

Fig.27

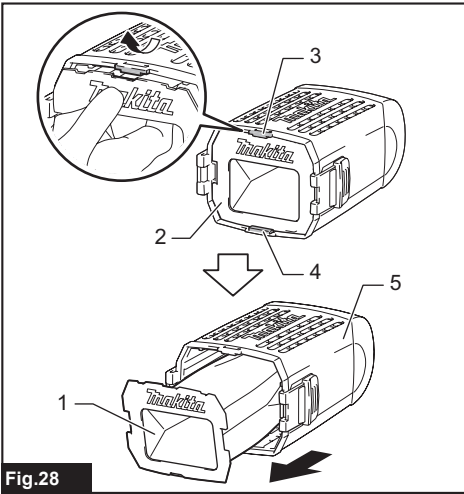

Fig.28

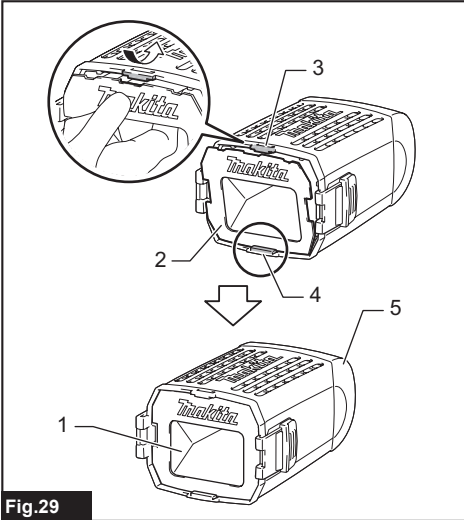

Fig.29

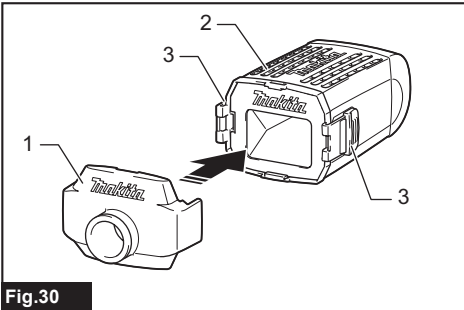

Fig.30

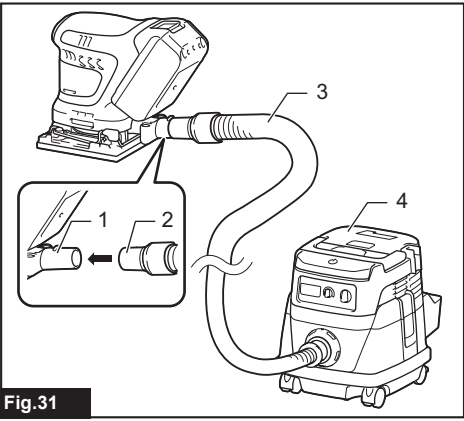

Fig.31

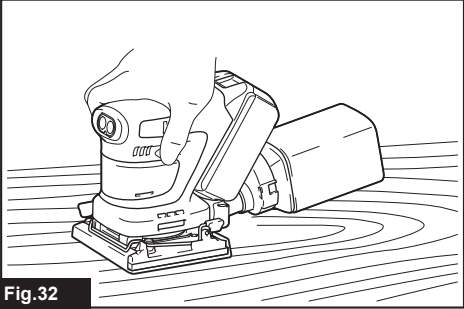

Fig.32

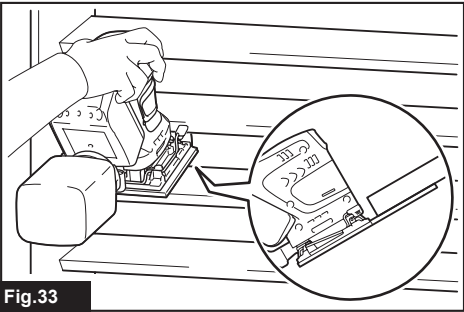

Fig.33

SPECIFICATIONS

Model:		DBO480	DBO481	DBO482
Pad size	Square pad	112 mm x 102 mm		
	Triangular pad	112 mm x 190 mm		
	Rectangular pad	112 mm x 168.5 mm		
Abrasive paper	For square pad (Hook and loop)	114 mm x 102 mm		
	For square pad (Clamp)	114 mm x 140 mm		
	For triangular pad	Rectangular paper: 114 mm x 102 mm Triangular paper: 96 mm		
	For rectangular pad	112 mm x 168.5 mm, 112 mm x 66 mm		
Orbits per minute	High	14,000 min ⁻¹		
	Low	11,000 min ⁻¹		
Overall length (with BL1860B)		171 mm		
Rated voltage		D.C. 18 V		
Net weight		1.4 - 1.7 kg		1.4 - 1.8 kg

- * The standard pad differs from country to country.
- Due to our continuing program of research and development, the specifications herein are subject to change without notice.
- Specifications and battery cartridge may differ from country to country.
- The weight may differ depending on the attachment(s), including the battery cartridge. The lightest and heaviest combinations, according to EPTA-Procedure 01/2014, are shown in the table.

Applicable battery cartridge and charger

Battery cartridge	BL1815N / BL1820B / BL1830B / BL1840B / BL1850B / BL1860B
Charger	DC18RC / DC18RD / DC18RE / DC18SD / DC18SE / DC18SF / DC18SH

- Some of the battery cartridges and chargers listed above may not be available depending on your region of residence.

⚠ WARNING: Only use the battery cartridges and chargers listed above. Use of any other battery cartridges and chargers may cause injury and/or fire.

Intended use

The tool is intended for the sanding of large surface of wood, plastic and metal materials as well as painted surfaces.

Noise

The typical A-weighted noise level determined according to EN62841-2-4:

Model DBO480

Sound pressure level (L_{pA}) : 75 dB(A)

Uncertainty (K) : 3 dB(A)

Model DBO481

Sound pressure level (L_{pA}) : 75 dB(A)

Uncertainty (K) : 3 dB(A)

Model DBO482

Sound pressure level (L_{pA}) : 75 dB(A)

Uncertainty (K) : 3 dB(A)

The noise level under working may exceed 80 dB (A).

NOTE: The declared noise emission value(s) has been measured in accordance with a standard test method and may be used for comparing one tool with another.

NOTE: The declared noise emission value(s) may also be used in a preliminary assessment of exposure.

⚠ WARNING: Wear ear protection.

⚠ WARNING: The noise emission during actual use of the power tool can differ from the declared value(s) depending on the ways in which the tool is used especially what kind of workpiece is processed.

⚠ WARNING: Be sure to identify safety measures to protect the operator that are based on an estimation of exposure in the actual conditions of use (taking account of all parts of the operating cycle such as the times when the tool is switched off and when it is running idle in addition to the trigger time).

Vibration

The vibration total value (tri-axial vector sum) determined according to EN62841-2-4:

Model DBO480

Work mode: sanding metal plate (square base)

Vibration emission (a_n): 2.5 m/s² or less

Uncertainty (K): 1.5 m/s²

Work mode: sanding metal plate (louver base)

Vibration emission (a_n): 4.1 m/s²

Uncertainty (K): 1.5 m/s²

Model DBO481

Work mode: sanding metal plate (square base)

Vibration emission (a_n): 2.5 m/s² or less

Uncertainty (K): 1.5 m/s²

Model DBO482

Work mode: sanding metal plate (square base)

Vibration emission (a_n): 3.4 m/s²

Uncertainty (K): 1.5 m/s²

NOTE: The declared vibration total value(s) has been measured in accordance with a standard test method and may be used for comparing one tool with another.

NOTE: The declared vibration total value(s) may also be used in a preliminary assessment of exposure.

⚠ WARNING: The vibration emission during actual use of the power tool can differ from the declared value(s) depending on the ways in which the tool is used especially what kind of workpiece is processed.

⚠ WARNING: Be sure to identify safety measures to protect the operator that are based on an estimation of exposure in the actual conditions of use (taking account of all parts of the operating cycle such as the times when the tool is switched off and when it is running idle in addition to the trigger time).

EC Declaration of Conformity

For European countries only

The EC declaration of conformity is included as Annex A to this instruction manual.

SAFETY WARNINGS

General power tool safety warnings

⚠ WARNING: Read all safety warnings, instructions, illustrations and specifications provided with this power tool. Failure to follow all instructions listed below may result in electric shock, fire and/or serious injury.

Save all warnings and instructions for future reference.

The term "power tool" in the warnings refers to your mains-operated (corded) power tool or battery-operated (cordless) power tool.

Sander safety warnings

1. Always use safety glasses or goggles. Ordinary eye or sun glasses are NOT safety glasses.
2. Hold the tool firmly.
3. Do not leave the tool running. Operate the tool only when hand-held.
4. This tool has not been waterproofed, so do not use water on the workpiece surface.
5. Ventilate your work area adequately when you perform sanding operations.
6. Some material contains chemicals which may be toxic. Take caution to prevent dust inhalation and skin contact. Follow material supplier safety data.
7. Use of this tool to sand some products, paints and wood could expose user to dust containing hazardous substances. Use appropriate respiratory protection.
8. Be sure that there are no cracks or breakage on the pad before use. Cracks or breakage may cause a personal injury.
9. Watch your footing and maintain your balance with the tool. Make sure there is no one below when working in high locations.

SAVE THESE INSTRUCTIONS.

⚠ WARNING: DO NOT let comfort or familiarity with product (gained from repeated use) replace strict adherence to safety rules for the subject product. MISUSE or failure to follow the safety rules stated in this instruction manual may cause serious personal injury.

Important safety instructions for battery cartridge

1. Before using battery cartridge, read all instructions and cautionary markings on (1) battery charger, (2) battery, and (3) product using battery.
2. Do not disassemble or tamper with the battery cartridge. It may result in a fire, excessive heat, or explosion.
3. If operating time has become excessively shorter, stop operating immediately. It may result in a risk of overheating, possible burns and even an explosion.
4. If electrolyte gets into your eyes, rinse them out with clear water and seek medical attention right away. It may result in loss of your eyesight.
5. Do not short the battery cartridge:
 - (1) Do not touch the terminals with any conductive material.
 - (2) Avoid storing battery cartridge in a container with other metal objects such as nails, coins, etc.
 - (3) Do not expose battery cartridge to water or rain.

A battery short can cause a large current flow, overheating, possible burns and even a breakdown.

6. **Do not store and use the tool and battery cartridge in locations where the temperature may reach or exceed 50 °C (122 °F).**
7. **Do not incinerate the battery cartridge even if it is severely damaged or is completely worn out. The battery cartridge can explode in a fire.**
8. **Do not nail, cut, crush, throw, drop the battery cartridge, or hit against a hard object to the battery cartridge.** Such conduct may result in a fire, excessive heat, or explosion.
9. **Do not use a damaged battery.**
10. **The contained lithium-ion batteries are subject to the Dangerous Goods Legislation requirements.**
For commercial transports e.g. by third parties, forwarding agents, special requirement on packaging and labeling must be observed.
For preparation of the item being shipped, consulting an expert for hazardous material is required.
Please also observe possibly more detailed national regulations.
Tape or mask off open contacts and pack up the battery in such a manner that it cannot move around in the packaging.
11. **When disposing the battery cartridge, remove it from the tool and dispose of it in a safe place. Follow your local regulations relating to disposal of battery.**
12. **Use the batteries only with the products specified by Makita.** Installing the batteries to non-compliant products may result in a fire, excessive heat, explosion, or leak of electrolyte.
13. **If the tool is not used for a long period of time, the battery must be removed from the tool.**
14. **During and after use, the battery cartridge may take on heat which can cause burns or low temperature burns. Pay attention to the handling of hot battery cartridges.**
15. **Do not touch the terminal of the tool immediately after use as it may get hot enough to cause burns.**
16. **Do not allow chips, dust, or soil stuck into the terminals, holes, and grooves of the battery cartridge.** It may cause heating, catching fire, burst and malfunction of the tool or battery cartridge, resulting in burns or personal injury.
17. **Unless the tool supports the use near high-voltage electrical power lines, do not use the battery cartridge near high-voltage electrical power lines.** It may result in a malfunction or breakdown of the tool or battery cartridge.
18. **Keep the battery away from children.**

SAVE THESE INSTRUCTIONS.

CAUTION: Only use genuine Makita batteries. Use of non-genuine Makita batteries, or batteries that have been altered, may result in the battery bursting causing fires, personal injury and damage. It will also void the Makita warranty for the Makita tool and charger.

Tips for maintaining maximum battery life

1. **Charge the battery cartridge before completely discharged. Always stop tool operation and charge the battery cartridge when you notice less tool power.**
2. **Never recharge a fully charged battery cartridge. Overcharging shortens the battery service life.**
3. **Charge the battery cartridge with room temperature at 10 °C - 40 °C (50 °F - 104 °F). Let a hot battery cartridge cool down before charging it.**
4. **When not using the battery cartridge, remove it from the tool or the charger.**
5. **Charge the battery cartridge if you do not use it for a long period (more than six months).**

FUNCTIONAL DESCRIPTION

CAUTION: Always be sure that the tool is switched off and the battery cartridge is removed before adjusting or checking function on the tool.

Installing or removing battery cartridge

CAUTION: Always switch off the tool before installing or removing of the battery cartridge.

CAUTION: Hold the tool and the battery cartridge firmly when installing or removing battery cartridge. Failure to hold the tool and the battery cartridge firmly may cause them to slip off your hands and result in damage to the tool and battery cartridge and a personal injury.

► Fig.1: 1. Red indicator 2. Button 3. Battery cartridge

To remove the battery cartridge, slide it from the tool while sliding the button on the front of the cartridge.

To install the battery cartridge, align the tongue on the battery cartridge with the groove in the housing and slip it into place. Insert it all the way until it locks in place with a little click. If you can see the red indicator as shown in the figure, it is not locked completely.

CAUTION: Always install the battery cartridge fully until the red indicator cannot be seen. If not, it may accidentally fall out of the tool, causing injury to you or someone around you.

CAUTION: Do not install the battery cartridge forcibly. If the cartridge does not slide in easily, it is not being inserted correctly.

Indicating the remaining battery capacity

Only for battery cartridges with the indicator

► Fig.2: 1. Indicator lamps 2. Check button

Press the check button on the battery cartridge to indicate the remaining battery capacity. The indicator lamps light up for a few seconds.

Indicator lamps			Remaining capacity
Lighted	Off	Blinking	
■	□	▧	75% to 100%
■	■	■	
■	■	□	50% to 75%
■	□	□	25% to 50%
■	□	□	0% to 25%
▧	□	□	Charge the battery.
■	■	□	The battery may have malfunctioned.
□	□	■	

NOTE: Depending on the conditions of use and the ambient temperature, the indication may differ slightly from the actual capacity.

NOTE: The first (far left) indicator lamp will blink when the battery protection system works.

Tool / battery protection system

The tool is equipped with a tool/battery protection system. This system automatically cuts off power to the motor to extend tool and battery life. The tool will automatically stop during operation if the tool or battery is placed under one of the following conditions:

Overload protection

When the tool or battery is operated in a manner that causes it to draw an abnormally high current, the tool automatically stops without any indication. In this situation, turn the tool off and stop the application that caused the tool to become overloaded. Then turn the tool on to restart.

Overheat protection

When the tool or battery is overheated, the tool stops automatically. In this case, let the tool and battery cool before turning the tool on again.

Overdischarge protection

When the battery capacity is not enough, the tool stops automatically. In this case, remove the battery from the tool and charge the battery.

Protections against other causes

Protection system is also designed for other causes that could damage the tool and allows the tool to stop automatically. Take all the following steps to clear the causes, when the tool has been brought to a temporary halt or stop in operation.

1. Turn the tool off, and then turn it on again to restart.
2. Charge the battery(ies) or replace it/them with recharged battery(ies).
3. Let the tool and battery(ies) cool down.

If no improvement can be found by restoring protection system, then contact your local Makita Service Center.

Switch action

CAUTION: Avoid turning the tool on while it is placed on the workpiece or on your workbench. It may cause personal injury or damage.

Turning the tool on and off

Press the power/speed select button to start the tool. The tool starts to run at its highest orbital speed. Press the stop button to stop the tool.

► Fig.3: 1. Power/speed select button 2. Stop button

Changing the tool speed

The orbital speed can be changed in two modes; high and low. Choose either mode depending on the application and workload. Press the power/speed select button to switch speed mode while the tool is running.

► Fig.4: 1. Power/speed select button

Speed settings table

Speed level	Orbital per minute
2 (High)	14,000 min ⁻¹ (/min)
1 (Low)	11,000 min ⁻¹ (/min)

NOTICE: If the tool is operated continuously at low speeds for a long time, the motor will get overloaded, resulting in tool malfunction.

NOTICE: Select an appropriate speed range for your sanding operations to avoid overheating and melting the workpiece. Sanding at high orbital speed may heat workpiece and melt it at the point of contact.

ASSEMBLY

CAUTION: Always be sure that the tool is switched off and the battery cartridge is removed before carrying out any work on the tool.

Installing and removing abrasive paper

CAUTION: Always make sure that a sheet of abrasive paper is installed securely before use. The paper may otherwise be loosened, removed easily and subject to slippage, resulting in uneven sanding operation.

NOTE: Bending the paper beforehand makes attachment easier.

Using abrasive paper without dust-suction hole

1. Cut a sheet of abrasive paper down to an appropriate size.
▶ **Fig.5:** 1. Abrasive paper 2. Pad
2. Push and hold down the clamp lever on either front or rear end of the pad, and slide it away from the stopper so the clamp is released from its locked position.
3. Pull the clamp lever outwards as far as possible to create a space between the clamp and side wall of the sanding base in which one end of abrasive paper can be inserted.
4. Slip one end of the abrasive paper into the space between the clamp and sanding base.
5. Reposition the abrasive paper so it is finely overlaid on the pad surface.
6. Set the clamp lever back in a locked position to clamp the end of abrasive paper securely.
7. Release the clamp on the other end, and have the other end of abrasive paper ready to be clamped.
8. Maintain a proper tension on abrasive paper, and then set the clamp lever on the other end in a locked position.
▶ **Fig.6:** 1. Abrasive paper 2. Clamp 3. Sanding base 4. Clamp lever 5. Stopper
9. Cover the abrasive paper with the punch plate with its positioning stoppers adjacent to the corner well fit onto two of the side edges of the pad and sanding base.
▶ **Fig.7:** 1. Abrasive paper 2. Punch plate 3. Positioning stoppers 4. Pad 5. Sanding base
10. Push the punch plate over the abrasive paper to make dust-suction holes.
11. To remove the abrasive paper, release the clamps on both ends and take the paper off the pad.

Using abrasive paper with dust-suction hole

Optional accessory

1. Push and hold down the clamp lever on either front or rear end of the pad, and slide it away from the stopper so the clamp is released from its locked position.
2. Pull the clamp lever outwards as far as possible to create a space between the clamp and side wall of the sanding base in which one end of abrasive paper can be inserted.
3. Place a sheet of abrasive paper over the pad, aligning the dust-suction holes in the paper with those in the pad.
▶ **Fig.8:** 1. Abrasive paper 2. Pad 3. Dust-suction hole
4. Slip one end of the abrasive paper into the space between the clamp and sanding base.
5. Set the clamp lever back in a locked position so the end of abrasive paper is clamped securely.
6. Release the clamp on the other end, and have the other end of abrasive paper ready to be clamped.

7. Maintain a proper tension on abrasive paper, and then set the clamp lever on the other end in a locked position.

▶ **Fig.9:** 1. Abrasive paper 2. Clamp 3. Sanding base 4. Clamp lever 5. Stopper

8. To remove the abrasive paper, release the clamps on both ends and take the paper off the pad.

Using hook-and-loop abrasive paper

CAUTION: Make sure to install a hook-and-loop pad correctly and securely. A loose attachment will run out of balance and cause an excessive vibration resulting in loss of control.

CAUTION: Be sure that a hook-and-loop pad and abrasive paper are aligned and securely attached.

CAUTION: Only use hook-and-loop abrasive papers. Never use pressure-sensitive abrasive papers.

For DBO480

1. Remove all dirt and foreign matter from the hook-and-loop pad.
2. Attach a sheet of optional hook-and-loop abrasive paper to the pad, aligning the dust-suction holes in the paper with those in the pad.
▶ **Fig.10:** 1. Abrasive paper 2. Pad 3. Dust-suction holes
3. To remove the abrasive paper, peel it off from the edge.

For DBO481 and DBO482

NOTICE: The cap or the O-ring may come out of the sanding base while replacing the pad. Be sure to set the cap or the O-ring back in the circular hole or the circular groove around the center of the base before installing the optional pad.

DBO481

▶ **Fig.11:** 1. Cap 2. Sanding base 3. Circular hole

DBO482

▶ **Fig.12:** 1. O-ring 2. Sanding base 3. Circular groove

1. Loosen and remove the four screws securing the pad to the sanding base.
▶ **Fig.13:** 1. Screws 2. Pad 3. Sanding base
2. Replace the standard-equipped pad with an optional hook-and-loop pad.
3. Re-tighten the screws firmly to secure the hook-and-loop pad.
▶ **Fig.14:** 1. Abrasive paper 2. Pad 3. Dust-suction holes
4. Remove all dirt and foreign matter from the hook-and-loop pad.
5. Attach a sheet of optional hook-and-loop abrasive paper to the pad, aligning the dust-suction holes in the paper with those in the pad.
▶ **Fig.15:** 1. Abrasive paper 2. Pad 3. Dust-suction holes
6. To remove the abrasive paper, peel it off from the edge.

Using triangular/rectangular abrasive paper

Optional accessory

CAUTION: Make sure to install a hook-and-loop pad correctly and securely. A loose attachment will run out of balance and cause an excessive vibration resulting in loss of control.

CAUTION: Be sure that a hook-and-loop pad and abrasive paper are aligned and securely attached.

CAUTION: Only use hook-and-loop abrasive papers. Never use pressure-sensitive abrasive papers.

NOTICE: The cap or the O-ring may come out of the sanding base while replacing the pad. Be sure to set the cap or the O-ring back in the circular hole or the circular groove around the center of the base before installing the optional pad.

DBO480, DBO481

► Fig.16: 1. Cap 2. Sanding base 3. Circular hole

DBO482

► Fig.17: 1. O-ring 2. Sanding base 3. Circular groove

1. Loosen and remove the four screws securing the pad to the sanding base.

► Fig.18: 1. Screws 2. Pad 3. Sanding base

2. Replace the standard-equipped pad with a triangular/rectangular pad.

3. Re-tighten the screws firmly to secure the triangular/rectangular pad.

Triangular pad

► Fig.19: 1. Screws 2. Triangular pad 3. Sanding base

You can install the abrasive paper on the side of the pad as illustrated.

► Fig.20: 1. Abrasive paper 2. Pad

Rectangular pad

► Fig.21: 1. Screws 2. Rectangular pad 3. Sanding base

4. Remove all dirt and foreign matter from the triangular/rectangular pad.

5. Attach a sheet of optional hook-and-loop abrasive paper to the triangular/rectangular pad, aligning the dust-suction holes in the paper with those in the pad.

Triangular pad

► Fig.22: 1. Abrasive paper 2. Triangular pad 3. Dust-suction holes

Rectangular pad

► Fig.23: 1. Abrasive paper 2. Rectangular pad 3. Dust-suction holes

6. To remove the abrasive paper, peel it off from the edge.

Installing and removing dust bag

Optional accessory

Attach the dust bag over the tapered dust spout at the back end of the motor housing. Put the dust inlet of the bag onto the dust spout as far as it will go to avoid it from coming off during operation.

► Fig.24: 1. Dust spout 2. Dust inlet 3. Dust bag

NOTICE: Do not hold the dust bag when carrying the tool. Otherwise, the tool may fall and be damaged.

NOTE: To ensure optimal dust collecting, empty the dust bag when it becomes filled to approximately half of its capacity.

Remove the dust bag from the tool and remove the dust nozzle. Then gently shake or tap the dust bag to empty.

► Fig.25: 1. Dust nozzle

Installing and removing dust box

Optional accessory

Attach the dust box over the tapered dust spout at the back end of the motor housing. Put the dust inlet onto the dust spout as far as it will go to avoid it from coming off during operation.

► Fig.26: 1. Dust spout 2. Dust inlet 3. Dust nozzle 4. Dust box

NOTICE: Do not hold the dust box when carrying the tool. Otherwise, the tool may fall and be damaged.

NOTE: To ensure optimal dust collecting, empty the dust box when it becomes filled to approximately half of its capacity.

1. Remove the dust box from the tool.
2. Detach the dust nozzle from the box while pressing and holding the locking latches on both sides of the box.
3. Gently shake or tap the dust box to empty.

Replacing paper filter

NOTICE: Be aware to align the logos on all the dust box, paper filter and dust nozzle in a consistent orientation when reassembling components.

1. Remove the dust box from the tool.
2. Detach the dust nozzle from the box while pressing and holding the locking latches on both sides of the box.
► Fig.27: 1. Dust nozzle 2. Dust box 3. Locking latch
3. Hold the inner top edge of the cardboard opening, and pull it off downwards to disengage the outer top edge of the cardboard opening from the upper hooking tab on the lip of the dust box.

4. Take the paper filter out of the dust box while pulling the outer bottom edge of the cardboard opening free from the lower hooking tab.

► **Fig.28:** 1. Paper filter 2. Cardboard opening 3. Upper hooking tab 4. Lower hooking tab 5. Dust box

5. Replace a paper filter by engaging the bottom edge of the cardboard opening in the lower hooking tab and push the top edge inwards until it clips into the upper hooking tab.

► **Fig.29:** 1. Paper filter 2. Cardboard opening 3. Upper hooking tab 4. Lower hooking tab 5. Dust box

6. Snap the dust nozzle into place while pressing and holding the locking latches on both sides of the dust box.

► **Fig.30:** 1. Dust nozzle 2. Dust box 3. Locking latch

Connecting with vacuum cleaner

Optional accessory

When you wish to perform clean sanding operation, connect a Makita vacuum cleaner to your tool. Use either an optional hose 28 mm or a combination of the front cuff 22 and hose provided with the cleaner to establish a connection.

► **Fig.31:** 1. Dust spout 2. Front cuff 3. Hose 4. Vacuum cleaner

OPERATION

Sanding operation

CAUTION: Always be sure that the workpiece is secured firmly.

NOTICE: Never run the tool without the abrasive paper. You may seriously damage the pad.

NOTICE: Never force the tool. Excessive pressure may decrease the sanding efficiency, damage the abrasive paper and/or shorten tool life.

Hold the tool firmly. Turn the tool on and wait until it attains full speed. Then gently place the tool on the workpiece surface. A finishing sander is generally used to remove only a small amount of material at a time. Since the quality of the surface is more important than the amount of stock removed, do not bear down on the tool. Keep the base flush with the workpiece at all times.

► **Fig.32**

You can sand the material with upper and down side of the pad when you sand with the triangular/rectangular pad. It is convenient when you sand an object such as louver.

► **Fig.33**

MAINTENANCE

CAUTION: Always be sure that the tool is switched off and the battery cartridge is removed before attempting to perform inspection or maintenance.

NOTICE: Never use gasoline, benzine, thinner, alcohol or the like. Discoloration, deformation or cracks may result.

To maintain product SAFETY and RELIABILITY, repairs, any other maintenance or adjustment should be performed by Makita Authorized or Factory Service Centers, always using Makita replacement parts.

After use

Wipe off the tool using a dry cloth or cloth slightly moistened with soapy water at regular intervals.

OPTIONAL ACCESSORIES

CAUTION: These accessories or attachments are recommended for use with your Makita tool specified in this manual. The use of any other accessories or attachments might present a risk of injury to persons. Only use accessory or attachment for its stated purpose.

If you need any assistance for more details regarding these accessories, ask your local Makita Service Center.

- Abrasive paper (hook and loop)
- Abrasive paper (clamp)
- Square pad (hook and loop)
- Square pad (clamp)
- Rectangular pad
- Triangular pad
- Dust bag
- Dust box
- Filter
- Paper filter
- Makita genuine battery and charger

NOTE: Some items in the list may be included in the tool package as standard accessories. They may differ from country to country.