



Assembly Instructions

Orka 3 Seat Lounge Set

(Product Codes: 65202062, 65203062,
65207062 & 65208062)

**PLEASE RETAIN THIS DOCUMENT ALONG WITH YOUR
PROOF OF PURCHASE FOR FUTURE REFERENCE**

Congratulations on your recent purchase of your beautiful Hartman furniture. We hope it brings you countless special moments with friends and family for many years to come.

Please follow these simple steps to build your furniture. We also have a very useful video available online to assist with the assembly, please visit www.hartmanuk.com

TOP TIPS

- Please read these instructions carefully before assembly, for further assistance please view our assembly video online for an easy step by step demonstration.
- Aluminium is a soft metal and over tightening may strip the thread or break the part, please loosely assembly your furniture before tightening to secure.
- Please **do not** use power tools, only use the tools provided in the bolt pack.
- Please allow 1 hour for assembly.
- This furniture can be assembled with **1** person; however, you may need someone to assist you when turning the furniture over into position.



Assembly Instructions

Orka 3 Seat Lounge Sofa

(65212062)











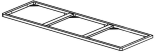

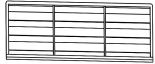
**PLEASE RETAIN THIS DOCUMENT ALONG WITH YOUR PROOF
OF PURCHASE FOR FUTURE REFERENCE**

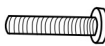
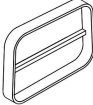
Congratulations on your recent purchase of your beautiful Hartman furniture. We hope it brings you bountiful special moments with friends and family for many years to come. Please follow these simple steps to build your furniture. We also have a very useful video available online to assist with the assembly, please visit www.hartmanuk.com

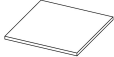
TOP TIPS

- Please read these instructions carefully before assembly. For further assistance please view our assembly video online for an easy step by step demonstration.
- Aluminium is a soft metal and over tightening may strip the thread or break the part, please loosely assemble your furniture before tightening to secure.
- Please **do not** use power tools, please use only the tools provided in the bolt pack.
- Please allow 1 hour for assembly
- This furniture can be assembled with **2** people; however, you may need someone to assist you when turning the furniture over into position.

PARTS LIST

Components					Fixings				
Parts List	Parts Picture	Description	Qty	Part No.	Parts List	Parts Picture	Description	Qty	Part No.
A		Seat Frame	1	65212062A	I		M6x16 Washer	14	1061162
B		Backrest	1	65212062B	J		M6x20 Bolt	4	1091162
C		Armrest 1	1	65212062C	K		M6x50 Bolt	10	1012162
D		Armrest 2	1	65212062D	L		Bolt Cap	14	1061163
E		Seat Panel	3	65212062E	M		M6 Allen Key	1	1010162
F		Centre Leg		65212062F	N		Feet	4	2SIF002
G		Back Cushion	3	65212062G	O		Adjustable Feet	2	2SIF009
H		Seat Cushion	3	65212062H					

STEP 1 & 2: ARMREST ASSEMBLY

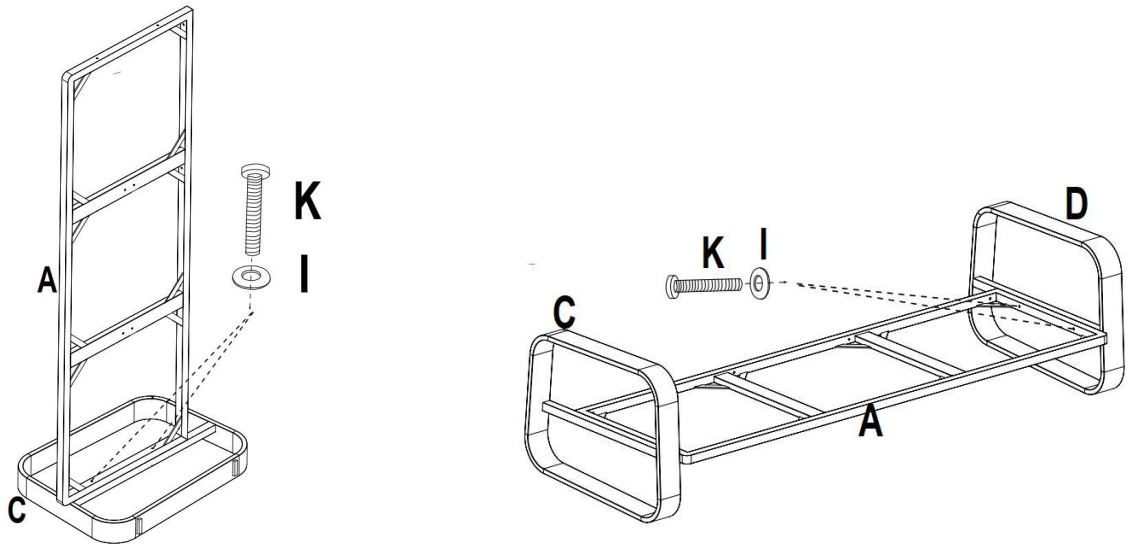

STEP 1: Attach Armrest1 (C) to the Seat Frame (A) using the M6x50 Bolt (K) and Washer (I)
STEP 2: Repeat STEP 1 with Armrest 2 (D)

STEP 3 & 4: BACKREST ASSEMBLY

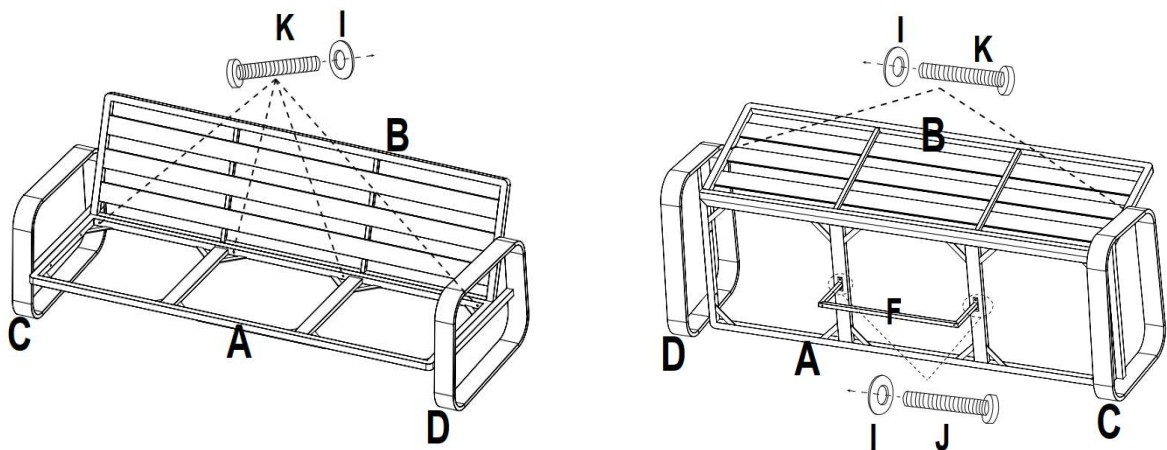

STEP 3: Attach Back Rest (B) to the Seat Frame (A) using the M6x50 Bolt (K) and Washer (I).
STEP 4: Attach Back Rest (B) to Armrest 1 (C) & Armrest 2 (D) using the M6x50 Bolt (K) and Washer (I). Attach Centre leg (F) to Seat Frame (A) using the M6x20 Bolt (J) and Washer (I).

STEP 5: TIGHTENING AND FINISHING

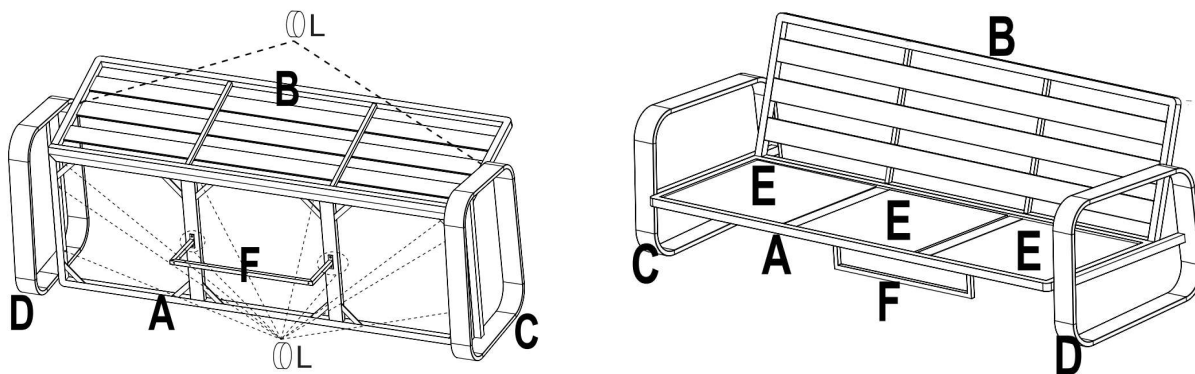

STEP 5: Tighten all the bolts on the sofa and cover with the Plastic bolt cap (L).
Turn the sofa over and place the Seat plate (E) and Seat cushion (H) and the Back cushion (G) onto the sofa.



Assembly Instructions

Orka Lounge Chair

(65203062)









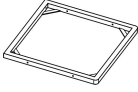

**PLEASE RETAIN THIS DOCUMENT ALONG WITH YOUR PROOF
OF PURCHASE FOR FUTURE REFERENE**

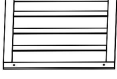
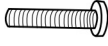
Congratulations on your recent purchase of your beautiful Hartman furniture. We hope it brings you bountiful special moments with friends and family for many years to come. Please follow these simple steps to build your furniture. We also have a very useful video available online to assist with the assembly, please visit www.hartmanuk.com

TOP TIPS

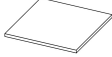
- Please read these instructions carefully before assembly. For further assistance please view our assembly video online for an easy step by step demonstration.
- Aluminium is a soft metal and over tightening may strip the thread or break the part, please loosely assemble your furniture before tightening to secure.
- Please **do not** use power tools, please only use the tools provided in the bolt pack.
- Please allow 1 hour for assembly.
- This furniture can be assembled by 1 person; however, you may need someone to assist you when turning the furniture over into position.

PARTS LIST

Components					Fixings				
Parts List	Parts Picture	Description	Qty	Part No.	Parts List	Parts Picture	Description	Qty	Part No.
A		Seat Frame	1	65203062A	H		Washer M6x16	8	1061162
B		Back Rest	1	65203062B	I		M6x50 Bolt	8	1061262
C		Armrest 1	1	65203062C	J		Bolt Cap	8	1061163
D		Armrest 1	1	65203062D	K		M6 Allen Key	1	1010162
E		Seat Panel (62x62cm)	1	65203062E (62x62cm)	L		Footpad	4	2SIF002
F		Back Cushion	1	65203062F					
G		Seat Cushion	1	65203062G					

STEP 1 & 2: ARMREST ASSEMBLY

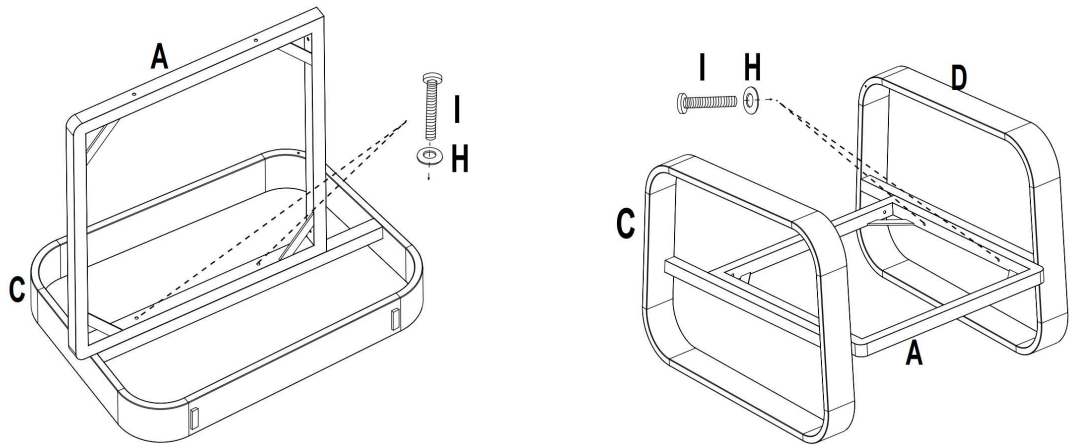

STEP 1: Attach Armrest1 (C) to the Seat Frame (A) using the M6x50 Bolt (I) and Washer (H)
STEP 2: Repeat step 1 with Armrest 2 (D)

STEP 3 & 4: BACKREST ASSEMBLY

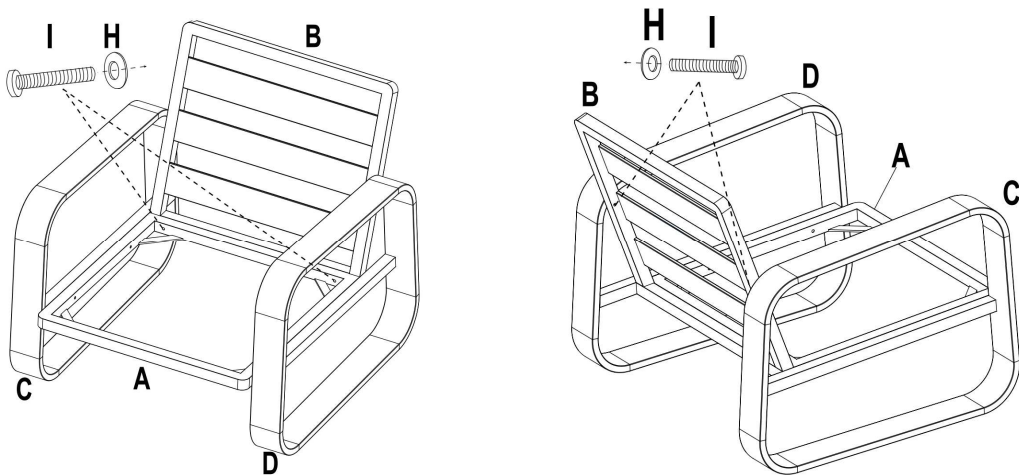

STEP 3: Attach Back Rest (B) to Seat Frame (A) using the M6x50 Bolt (I) and Washer (H).
STEP 4: Attach Back Rest (B) to Armrest 1 (C) & Armrest 2 (D) using the M6x50 Bolt (I) and Washer (H).

STEP 5: TIGHTENING AND FINISHING

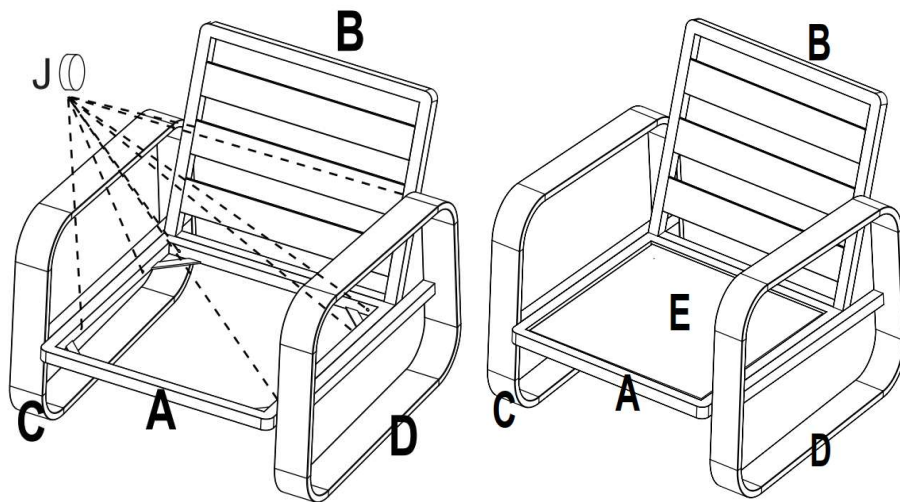

STEP 5: Tighten all the bolts on the chair and add the bolt caps (J). Turn the chair over and place the seat panel (E) followed by the seat cushion (G) and the back cushion (F).



Assembly Instructions

Orka Rectangular Adjustable Table (Product Codes: 65207062 & 65208062)











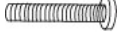
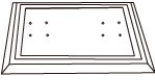
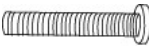
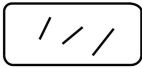

**PLEASE RETAIN THIS DOCUMENT ALONG WITH YOUR
PROOF OF PURCHASE FOR FUTURE REFERENCE**

Congratulations on your recent purchase of your beautiful Hartman furniture. We hope it brings you bountiful special moments with friends and family for many years to come. Please follow these simple steps to build your furniture. We also have a very useful video available online to assist with the assembly, please visit www.hartmanuk.com

TOP TIPS

- Please read these instructions carefully before assembly. For further assistance please view our assembly video online for an easy step by step demonstration.
- Aluminium is a soft metal and over tightening may strip the thread or break the part, please loosely assemble your furniture before tightening to secure.
- Please **do not** use power tools, only use the tools provided in the bolt pack.
- Please allow **1 hour** for assembly.
- This furniture can be assembled with **2** people; however, you may need someone to assist you when turning the furniture over into position.

PARTS LIST

Components					Fixings				
Parts List	Parts Picture	Description	Qty	Part No.	Parts List	Parts Picture	Description	Qty	Part No.
A		Table Top	1	65207062A	E		M6x25 Bolt	2	1017162
B		Leg Pillar	1	65208062B	F		M6x35 Bolt	2	1111162
C		Base	1	65207062A	G		M8x55 Bolt	8	2002166
D		Glass	1	65207062A	H		M6*φ12 Washer	10	1241162
					I		M8*φ20 Washer	8	1061191
					J		M6 Bolt Cap	10	1061163MG
					K		M8 Bolt Cap	8	1061164MG
					L		M6 Lock Washer	10	1051163
					M		M8 Lock Washer	8	1063162
					N		M6 Allen Key	1	1010162
					O		M8 Allen Key	1	1051162
					P		Adjustable Foot	4	2SIF009MG
					Q		Sucker	12	1241164

STEP 1 & 3: PILLAR ASSEMBLY

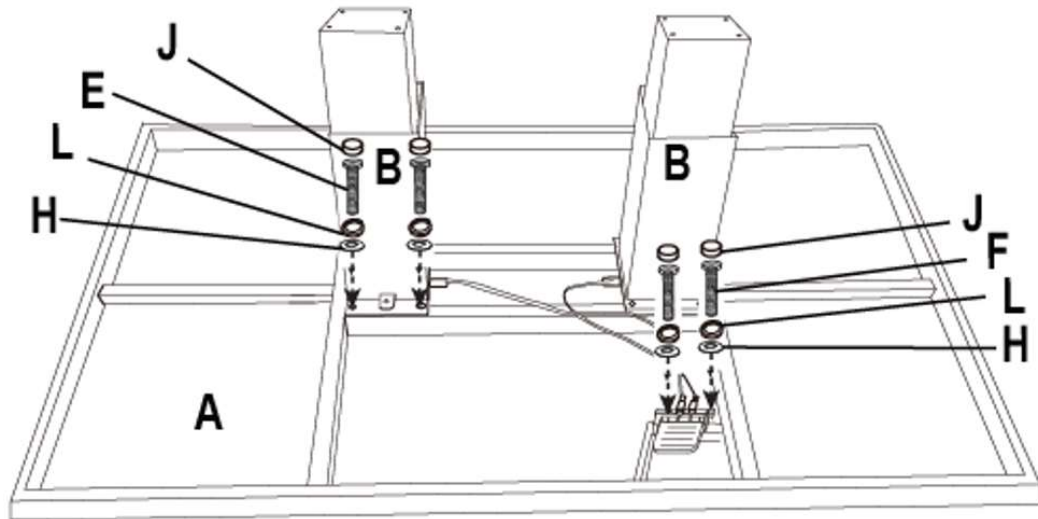

STEP 1: Attach leg pillar (B) to the table top (A), using the M6x25 bolt (E), lock washer (L) and washer (H).

STEP 2: Attach the handle to the Table top (A), using the M6x35 bolt (F), lock washer (L) and washer (H).

Tighten all the bolts and cover with the bolt cap (J)

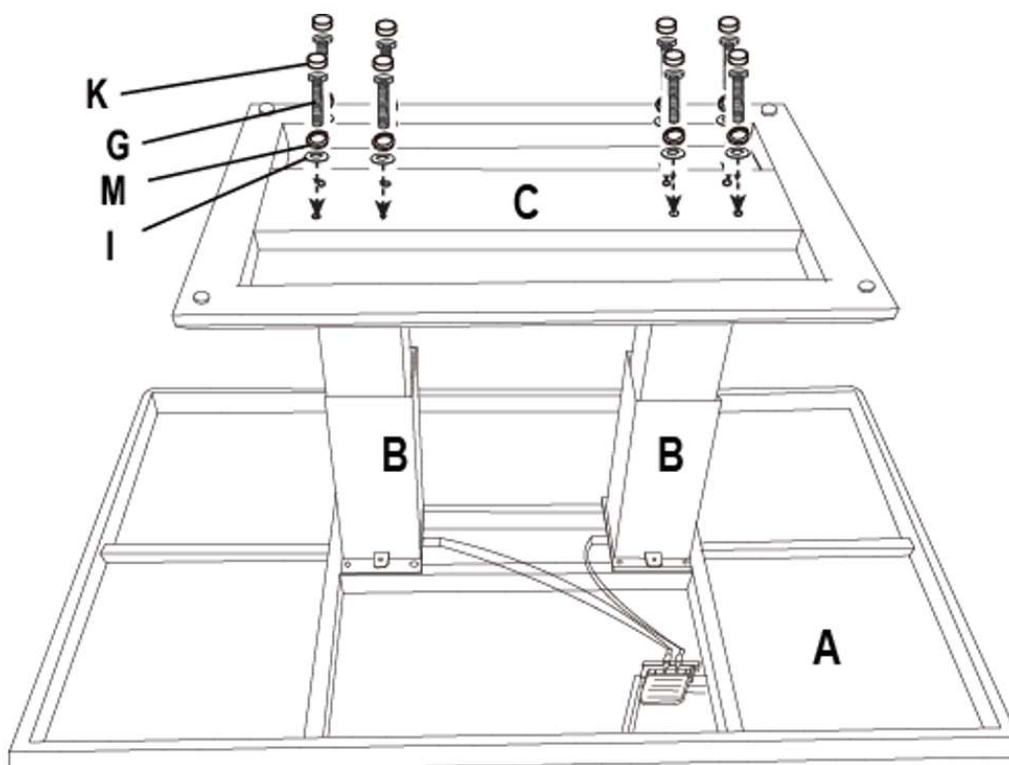

STEP 3: Attach base (C) to the leg pillar (B), using the M8x55 bolt (G), lock washer (M) and washer (I)
Tighten all the bolts and cover with the bolt cap (K)

STEP 4: COMPLETE AND TRY LIFT FUNCTION

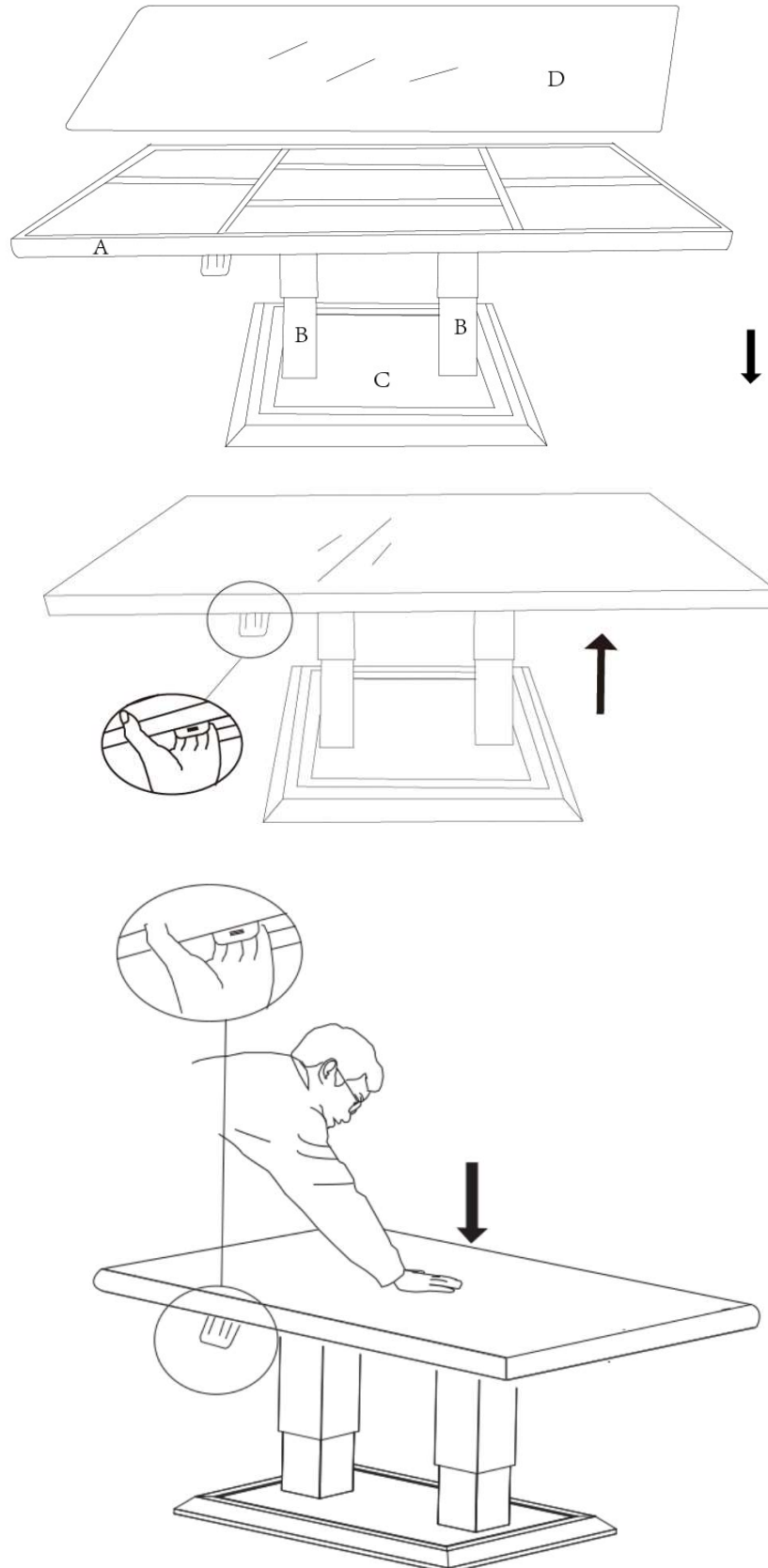

STEP 4: Turn the table over and place the glass (D) onto the table
To raise the table, firmly squeeze the handle. To lower the table, gently press the centre of the tabletop while squeezing the handle.